

Altitude 350-2



Altitude 350-2 integrated and detachable dual-radio access points provide secure, high-performance wireless coverage for demanding enterprise applications.

Simplicity

- Dual radios and power options maximize design options and flexibility settings
- Dynamic Radio Management (DRM) eliminates management of channel settings and power levels
- AccessAdapt™ with branch office support provides Plug-and-Play AP installation without pre-configuration

Performance

- Antenna diversity for clear, clean signals
- Automated radio self-healing for high availability
- Over-the-air Quality of Service (QoS) with automatic mapping to wired QoS for true end-to-end voice support
- Hardware-accelerated encryption in every Access Point (AP) for fast, scalable link security

Security

- Directory-integrated link security simplifies user access management
- A rich set of authentication and access control options for every application and device
- Wireless intrusion detection that operates while user connections are being maintained

Altitude 350-2 is a dual-radio AP that supports simultaneous operation of 802.11a and 802.11b/g wireless networks. Used with Summit® WM series controllers for centralized management and control, the Altitude 350-2 APs deliver Plug-and-Play installation anywhere in the organization's network, including the next building, the next city or even in another continent. Two Altitude 350-2 models are available: the sleek integrated model with internal omni-directional antennas and the detachable model that provides RP-SMA connectors for external antennas. Both models support antenna diversity for better performance, particularly in challenging multipath environments.

Altitude 350-2 delivers an easy-to-use, secure and high-performance solution that is ideal for demanding enterprises. With the versatility to simultaneously support a wide variety of wireless needs—including voice access, guest access, secured access and rogue AP detection—Altitude 350-2 dramatically simplifies the installation and operation of enterprise wireless networks. This AP can be installed without major network topology changes, without significant network reconfiguration, without time-consuming pre-configuration steps and without skilled labor at the site.

Target Applications

- Wireless connectivity for multiple user types and devices
- Support for high-performance applications such as Voice over WLAN (VoWLAN)
- Distributed wireless connectivity with Plug-and-Play installation and centralized support
- Applications requiring high availability and radio frequency management
- Sites requiring both connectivity and wireless intrusion detection

Together with Summit WM series controllers for centralized management, Altitude 350-2 delivers Plug-and-Play installation anywhere in an organization's network—including the next building, next city or even in another country.



Simple Installation and Operation

Out-of-the-box Altitude 350-2 AP installation is easy. Using AccessAdapt, Altitude 350-2 automatically discovers connections to the Summit WM series controller. No changes to the network topology or new VLANs are necessary—making the solution easy to integrate with existing networks. After discovering the Summit WM series controller, Altitude 350-2 AP downloads configuration details and provisioning information. Using multiple Service Set Identifiers (SSIDs), designers can make a rich set of access options available to users of a single AP. For example, one Altitude AP can simultaneously support guests, VoWLAN handsets and secured employee access.

Maximize Flexibility with Dual Radios, Power Choices and Mounting Options

Altitude 350-2 APs support two 802.11 WLAN radios, maximizing design options for user support and perimeter defense. When both radios are utilized, enterprises benefit from having the maximum aggregate capacity available at every service location. Each radio can support multiple applications, such as voice, corporate or guests, to tailor performance for demanding applications. The AP is plenum rated and supports Power over Ethernet (PoE) or external power (adapters are sold separately), giving installers the flexibility to meet site demands for device placement.

Dynamic Radio Management (DRM)

Altitude 350-2 APs provide DRM. DRM automatically assigns power levels and channels, continually adjusts radio frequency characteristics while the system is in operation, and self-heals the network should an AP go out of service. As a result, Altitude 350-2 delivers fewer dropouts and lost connections, clearer calls and higher system throughput.

DRM operations can be tailored to meet site, performance and security demands. For the highest aggregate throughput and best roaming performance, DRM minimizes co-channel interference by providing “shaped” radio frequency coverage. With cell shaping, transmit power is dynamically limited to the

lowest level possible, while management frames (beacons) are transmitted at maximum power. This allows roaming clients (such as VoWLAN handsets) to easily and quickly locate radio resources and roam to adjacent cells. When cell shaping is disabled, Altitude limits beacon transmission power levels, adding an extra measure of security by making wireless networks harder to detect outside the facility.

DRM even works to optimize the network when “foreign” wireless networks or interference sources are in range. If an interfacing signal is detected, DRM will automatically select channels and power levels to minimize the impact.

Enterprise Voice-Grade Performance and Availability

Altitude 350-2 APs and Summit WM series controllers work together to optimize performance and availability for voice. All 802.11 time-critical functions, such as hardware-accelerated encryption, over-the-air QoS and radio frequency management are implemented on Altitude 350-2. This delivers higher performance, more scalability and robust availability—particularly in large networks—than wireless LAN alternatives that rely on a central appliance to manage time-critical functions. Altitude 350-2 also supports over-the-air QoS protocols such as SpectraLink Voice Priority (SVP) and 802.11e based WMM specifications.

Altitude 350-2 supports Call Admission Control (CAC) per IEEE 802.11e based Traffic Specifications (TSPEC). CAC facilitates fast roaming of voice clients by regulating the number of calls handled by the AP to ensure delivery of QoS and prevent oversubscription of network resources. In addition, Altitude 350-2 also speeds roaming by supporting the QoS Basis Service Set (QBSS) Information Element, which broadcasts the AP loading to the clients. With it, clients can make intelligent roaming decisions by associating with APs that are lightly loaded.

And finally, Altitude 350-2 supports standards based (802.11e) Unscheduled Automatic Power Save Delivery (U-APSD) that extends the battery life of handheld client devices like VoWLAN handsets. Altitude 350-2 facilitates high availability in two ways. First of all, if an AP fails,

other APs in the vicinity will use DRM to sense the lower power and boost their power to provide coverage. Secondly, Altitude 350 participates in load sharing redundancy. Summit WM controllers are paired so each can assume the load of the other during a failure. Should either controller fail, its Altitude APs connect to the backup controller.

High Performing Branch Office Support

Altitude 350-2s can also be deployed in remote offices without needing a remote Summit WM controller. In this configuration, the APs locally bridge wireless traffic and use local security and QoS policies. Communication with the central Summit WM controller is needed only during boot up and for user authentication. Branch Office mode is more economical than competitive solutions (a controller is not needed at every branch site), provides better performance and offers survivability as local wireless user sessions stay operational even when the WAN connection is not available.

Enterprise-Grade Security

Altitude 350-2 APs work with Summit WM controllers and the enterprise's existing AAA infrastructure to deliver comprehensive link security capabilities. The solution offers a complete range of privacy options ranging from unencrypted communication for guests, shared key for phones and PDAs, to WEP, WPA and WPA2. For high-performance and scalability, all over-the-air encryption connections are terminated at Altitude 350-2 with hardware-accelerated encryption.

Altitude 350-2 also supports intrusion detection of rogue APs or unauthorized ad hoc networks. Each AP can scan multiple bands and channels to detect unauthorized wireless devices while simultaneously supporting user connections. The data from these scans is transmitted to a Summit WM controller where it is analyzed and reported so action can be taken.

For greater physical security, Altitude 350-2 has no console port to access and is mounted with a bracket that requires tools for removal. Security is not compromised if an Altitude 350-2 is stolen. All data is erased when the unit is unplugged.

Product Specifications

Physical Specifications

Unit Dimensions

- 7.4 in. (18.8 cm) wide; 5.6 in. (14.2 cm) deep;
- 1.6 in. (4.1 cm) high

Weight

- 12.2 oz (346g); add 2.6 oz (74g) for mounting bracket

Packaging Specifications

- 9.5 in. (24.1 cm) wide; 10.5 in. (26.7 cm) deep;
- 2 in. (5.1 cm) high
- 2 lbs (0.91 kg)

Operating

- Operating temperature 5° C to 40° C (41° F to 104° F)
- Storage temperature -40° C to 85° C (-40° F to 185° F)
- Relative Humidity 10 - 95% (Non-Condensing)
- Altitude 0 - 3000 meters (9,850 ft)

Transportation

- Shock 3G, 11ms, 60 Shocks
- Shock 10G, 6ms, 600 Shocks
- Sine Vibration 5-100-5 Hz @.2G, 0-peak, 1/10 Oct/min
- Random Vibration 3-500Hz 1.5Grms
- Random Vibration 5-20Hz @ 1.0 ASD W/-3dB/oct from 20-200Hz
- Drop at 39.4", 14 drops, packaged

Input Power

Power over Ethernet (PoE)

- 48VDC, 250mA via Power over Ethernet (PoE) Switch (Class 0, 12.95 Watts Max, 7.4 Watts Typical)
- 48VDC, 250mA via Power over Ethernet (PoE) Injector (Not Provided)

Wall Adapter

- 6VDC, 1.5A, (Not Provided) Requires country specific certifications

Interface

- Auto-sensing 10/100 Ethernet interface

LEDs

- 2.4 GHz Radio Activity
- Access Point Power/Status
- 5.0 GHz Radio Activity

Antenna Internal Diversity

- 2.4 GHz – 2 dBi Gain
- 5.0 GHz – 5 dBi Gain

External Antenna (Detachable A-350 only)

- RP-SMA Connector 2.4 GHz – 4 dBi Gain
- 5.0GHz – 5 dBi Gain

Frequency Bands

- 2.4 GHz to 2.4835 GHz (FCC/ETSI)
- 2.4 GHz to 2.497 GHz (Japan)
- 5.15 GHz to 5.850 GHz
- FCC: Up to 13 non-overlapping channels
- ETSI: Up to 19 non-overlapping channels
- Japan: 8 non-overlapping channels
- Wireless Modulation
 - 802.11a: OFDM
 - 802.11b: DSSS/CCK
 - 802.11g: DSSS/CCK/OFDM

- Dynamic Channel Control
 - DFS & TPC supported in Europe and Japan
- Data Rates
 - 802.11a: 6, 9, 12, 18, 24, 36, 48, 54 Mbps
 - 802.11b: 1, 2, 5.5, 11 Mbps
 - 802.11g: 1, 2, 5.5, 6, 9, 11, 12, 18, 24, 36, 48, 54 Mbps

Maximum Transmit Power

Altitude 350-2i (2610):

- 802.11a
 - 5.15 to 5.25 GHz: 17/16.5/18 dBm (FCC/ETSI/Japan)
 - 5.25 to 5.35 GHz: 18/16.5/18 dBm (FCC/ETSI/Japan)
 - 5.47 to 5.725 GHz: 18 dBm (ETSI)
 - 5.725 to 5.825 GHz: 15 dBm (FCC)
- 802.11b: 18/15/18 dBm (FCC/ETSI/Japan)
- 802.11g: 18/15/18 dBm (FCC/ETSI/Japan)

Altitude 350-2d (2620):

- 802.11a
 - 5.15 to 5.25 GHz: 17/16.5/18 dBm (FCC/ETSI/Japan)
 - 5.25 to 5.35 GHz: 18/16.5/18 dBm (FCC/ETSI/Japan)
 - 5.47 to 5.725 GHz: 18 dBm (ETSI)
 - 5.725 to 5.825 GHz: 15 dBm (FCC)
- 802.11b: 18/15/18.5 dBm (FCC/ETSI/Japan)
- 802.11g: 18/15/18.5 dBm (FCC/ETSI/Japan)

Transmit – (Selectable per Radio)

100%, 50%, 25%, 12.5%, 6.25%

Receive Sensitivity

- 802.11b:
 - 1 Mbps/-91 dBm,
 - 2 Mbps/-90 dBm,
 - 5.5 Mbps/-89 dBm,
 - 11 Mbps/-87 dBm
- 802.11a:
 - 6 Mbps/-89 dBm,
 - 36 Mbps/-78 dBm,
 - 48 Mbps/-73 dBm,
 - 54 Mbps/-70 dBm
- 802.11g:
 - 6 Mbps/-89 dBm,
 - 36 Mbps/-79 dBm,
 - 48 Mbps/-74 dBm,
 - 54 Mbps/-72 dBm

Regulatory/Safety

Safety

- cULus per 60950-1:2003
- UL2043 Plenum Rated
- CB per IEC 60950-1:2001 with all available country deviations
- GS Mark per EN60950-1:2001
- 73/23/EEC Low Voltage Directive
- North America EMC Standards
 - FCC 47 CFR, Part 15.107, 15.109, Class A (USA)
 - ICES-003 Class A (Canada)

European EMC Standards

- EN 55022:2003 Class A
- EN 55024:1998 Class A includes IEC/EN 61000-4-2, 3, 4, 5, 6, 11
- EN 61000-3-2,3 (Harmonics & Flicker)
- ETSI EN 300 386:2001 (EMC Telecommunications)
- ETSI EN 300 486-17 (9-2000)
- EN60601-1-2 (Medical)
- 89/336/EEC EMC Directive

International EMC Standards

- CISPR22:2003:A1:2004 Class A (International Emissions)
- CISPR 24:1997 Class A (International Immunity)
- IEC/EN 61000-4-2 Electrostatic Discharge
- IEC/EN 61000-4-3 Radiated Immunity
- IEC/EN 61000-4-4 Transient Burst
- IEC/EN 61000-4-5 Surge
- IEC/EN 61000-4-6 Conducted Immunity
- IEC/EN 61000-4-11 Power Dips & Interruptions

Radio Transceiver Compliance

USA

- FCC 47 CFR, Part 15.247, Class C (2.4GHz)
- FCC 47 CFR, Part 15.407, Class C (5GHz)
- FCC 47 CFR, Part 15.205, 15.207, 15.209
- FCC 47 CFR, Part 2.109, 2.1093
- FCC OET No. 65:1997
- FCC ID#RFJ-A3502

Canada

- RSS-210 (2.4GHz)
- RSS-139-1 (5GHz)
- RSS-102 (RF Exposure)
- IC ID# 4141A-A3502

European Union

- R&TTE Directive 1999/5/EC
- ETSI/EN 300 328-2 2003-04 (2.4 GHz)
- ETSI/EN 301 893-1 2002-07 (5 GHz)
- ETSI/EN 301 489-1 2002-08
- ETSI/EN 301 489-17 2002-08 (RLAN)

Note: For latest compliance standards, Declarations of Conformity (DoC) and country specific certifications visit www.extremenetworks.com/go/rfcertification.htm.

Other

- IEEE 802.11a (5 Ghz)
- IEEE 802.11b/g (2.4 GHz)
- IEEE 802.3af (PoE)

Environmental Standards

- EN/ETSI 300 019-2-1 v2.1.2 – Class 1.2 Storage
- EN/ETSI 300 019-2-2 v2.1.2 – Class 2.3 Transportation
- EN/ETSI 300 019-2-3 v2.1.2 – Class 3.1e Operational
- ASTM D3580 Random Vibration Operational 1.5G

Accessories

Ceiling Mount Bracket Kit for Altitude 350-2 Access Point (AP)

Customers wishing to install an Altitude 350-2 AP to the T-Bar of a drop down ceiling can utilize this optional accessory from Extreme Networks. This product is a package of five ceiling mount bracket kits.



Product Description

Each of the five ceiling mount bracket kits consists of (1) ceiling-mount bracket, (2) nylon spacers, (1) snap rivet and (2) T-Bar clips (see Figure 1). The ceiling-mount bracket snaps to the base of the Altitude 350-2 housing. The T-Bar clips and nylon spacers facilitate mounting the bracket with the AP to the T-Bar on the drop ceiling, as shown in Figure 2.

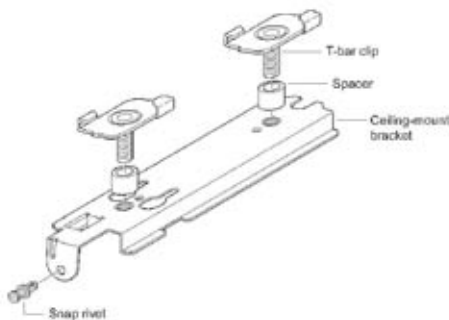

Figure 1: Ceiling Mount Bracket Kit

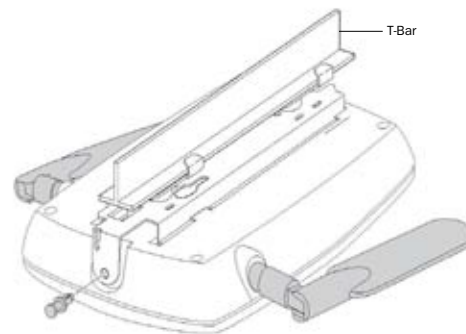

Figure 2: Mounting Access Point to T-Bar

Features

- Snap tight installation.
- Easy mounting to T-Bar. Does not damage or mar the T-Bar.
- Facilitates proper placement of APs across the coverage area, enables better and uniform wireless coverage for wireless users.
- Easy to remove and re-use if needed.

Product Specifications

- Weight (each bracket Kit): Approx. 4 oz (113 grams)
- Weight (box of 5 brackets): Approx. 2 lbs (907 grams)
- Dimensions—Bracket: Approx. 6.8 x 1.9x 0.9 (inches); 173.2 x 47.7 x 22.9 (mm)
- Dimensions—Package (box of 5 kits): 8 x 6 x 3 (inches); 203.2 x 152.4 x 76.2 (mm)
- RoHS 6 compliant

Ordering Information

Part Number	Name	Description
15938	Altitude 350-2 Integ. Ant. AP	Dual-radio Access Point capable of supporting 802.11a/b/g standards; requires Summit WM series controller for operation. Includes internal antennas and standard mounting bracket. Use 802.3af PoE or optional external Altitude 350 AC to DC 6V adapter. Recommended for vertical wall mounting and not horizontally on the ceiling due to antenna pattern
15939	Altitude 350-2 Detach. Ant. AP	Dual-radio Access Point capable of supporting 802.11a/b/g standards; requires Summit WM series controller. Includes bracket and two 15931 "paddle" external antennas. Use 802.3af PoE or optional external Altitude 350 AC to DC 6V adapter. Two RP-SMA connectors
15925	Altitude 350 AC PSU, NA	External Power Adapter for the Altitude 350, AC to 6 Volt DC, U.S./Canada only
15926	Altitude 350 AC PSU, EMEA	External Power Adapter for the Altitude 350, AC to 6 Volt DC, European Union
15928	Altitude 350 AC PSU, GBR	External Power Adapter for the Altitude 350, AC to 6 Volt DC, United Kingdom
15920	A350 Ceil Mt Brkt Kit (5 pack)	Pack of 5 ceiling mount bracket kits for Altitude 350-2 Access Points. Each mounting bracket kit is used to mount one Altitude 350-2 upside down on the T-Bar of a drop ceiling



www.extremenetworks.com

email: info@extremenetworks.com

Corporate and North America
 Extreme Networks, Inc.
 3585 Monroe Street
 Santa Clara, CA 95051 USA
 Phone +1 408 579 2800

Europe, Middle East, Africa and South America
 Phone +31 30 800 5100

Asia Pacific
 Phone +852 2517 1123

Japan
 Phone +81 3 5842 4011

© 2007 Extreme Networks, Inc. All rights reserved.
 Extreme Networks, the Extreme Logo, AccessAdapt, and Summit are either registered trademarks or trademarks of Extreme Networks, Inc. in the United States and/or other countries.
 Specifications are subject to change without notice.