

Megaplex Modules

VC-4/4A, VC-8/8A, VC-16

4/8/16-Channel PCM and ADPCM Voice Modules

Provide 4, 8 or 16 analog voice channels using 64 kbps toll-quality PCM encoding; 24/32 kbps ADPCM encoding option for 4- and 8-channel modules

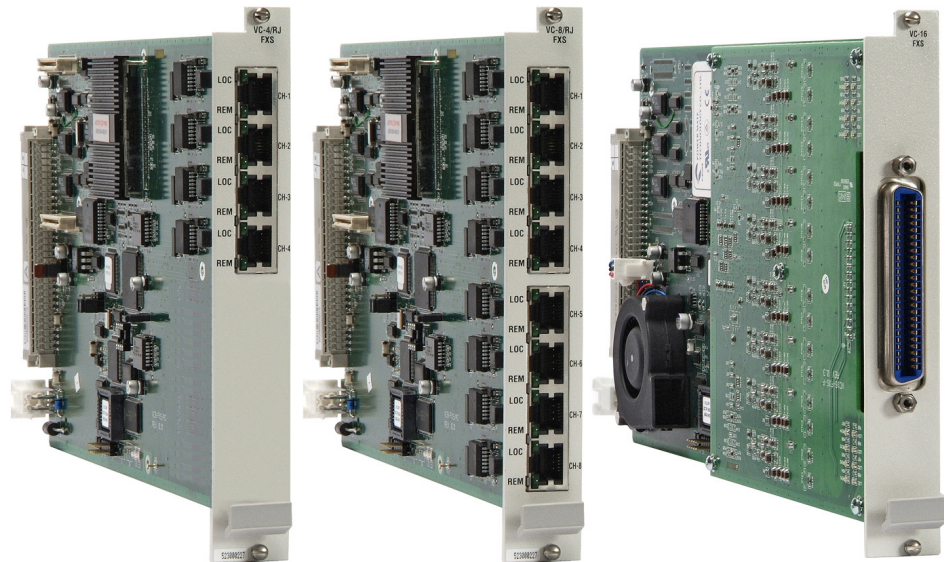

- E&M, FXS or FXO interface options
- Caller ID
- A-law or μ -law companding
- Optional inband signaling with A-law encoded channels
- PCM (64 kbps) and ADPCM (24 or 32 kbps) encoding

The VC-4, VC-8 and VC-16 modules provide 4, 8 or 16 toll-quality voice channels. Voice signals are digitized using PCM, in compliance with ITU-T G.711 and AT&T Pub. 43801 standards, enabling up to 30 voice channels to be transmitted over an E1 link, or 24 voice channels over a T1 link.

The VC-4A and VC-8A modules, in addition to PCM 64 kbps encoding, employ toll-quality 24 or 32 kbps ADPCM voice compression encoding.

Note: Unless otherwise specified, "VC modules" in this datasheet refer to all 5 modules.



data communications

The Access Company

VC-4/4A, VC-8/8A, VC-16

4/8/16-Channel PCM and ADPCM Voice Modules

The maximum number of channels achieved for the Megaplex-2100/2104 depends on the Megaplex chassis, type of encoding, type and number of main link modules, and the number of VC modules in the chassis. For example, a MP-2100 equipped with 8 VC-16 modules, in conjunction with 4 channels of ML-8E1, can provide up to 124 voice channels.

MP-4100 equipped with 10 VC-16 modules can support 160 channels over SONET/SDH. For operation in E1/T1 environment, 9 VC-16 modules, in conjunction with ML-8E1, can provide up to 144 voice channels.

Encoding and decoding are in full compliance with ITU-T requirements G.712, G.713 and G.714. Voice channel companding is selectable for A-law or μ -law.

Each 64 kbps PCM voice channel is allocated a timeslot on a link in a DS0 compatible format, permitting voice channel switching in systems based on digital cross-connect (DACs). Each channel can be independently routed to any link.

Each ADPCM voice channel (32 or 24 kbps) is allocated half a timeslot on a link in a DS0 compatible format.

Each VC voice channel supports Caller ID by transparently transferring the FSK modem tones between the incoming rings. With this feature, a customer subscribed to a Caller ID service can see the Caller ID of an incoming or waiting call with any Caller ID display equipment.

VC voice channels support SMS message transfer between the telephones using DECT protocol.

The modules are available with the following interface types:

E&M interface for operating with different types of E&M signaling: EIA RS-464 Types I, II, III and V (British Telecom SSSDC5). Both 2-wire and 4-wire lines are supported (user-selectable). Typically used for connection of tie lines between PBXs (see *Figure 1*).

The E&M modules support the EIA RS-464 Type I signaling standard without the need for an external DC power supply. For the other signaling standard types, the internal -12 VDC provided by the chassis is sufficient for connection to most PBX systems.

However, for *full* support of EIA RS-464 Types II, III and V (BT SSSDC5) standards, a -48 VDC power source is required.

A special **E&M/POS** version of VC-8 and VC-16 with positive signaling is available for use in radio transmitter applications, enabling the module signaling operation at +5V or +12V.

FXS interface supporting both loop-start and wink-start signaling methods. FXS interfaces are typically used for direct connection to 2-wire telephones in the following loop-start applications:

- Off-Premises Extension (OPX), where a local telephone on the PBX can be connected to an off-premises telephone, by dialing only the extension number assigned to the off-premises telephone (see *Figure 2*);
- Private Line, Automatic Ringdown application (PLAR) (also referred to as Hot Line), where two telephones are connected directly via the E1/T1 link. When the telephone on one side goes off-hook, the other telephone rings;
- Direct connection to 2-wire telephones in PSTN applications.



Figure 1. VC-16/E&M Connecting 16 Tie Lines between PBXs

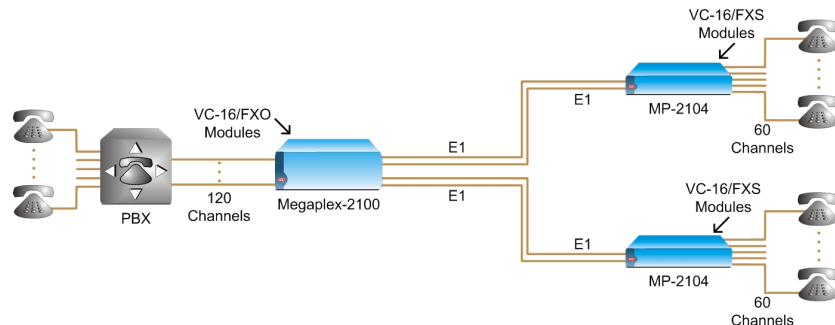

Figure 2. Multipoint, Off-Premises Extension of 120 PCM Voice Channels Using Four E1 Links

When operating in PCM mode, battery polarity reversal is supported for wink-start signaling, which is used for direct inward dialing (DID) applications. The FXS VC modules also generate 12/16 kHz metering pulse for connection to public payphones (see *Figure 3*).

FXO interface supporting both loop-start and wink-start signaling methods. Can be used for connection to PBX extension lines in point-to-point loop-start applications, opposite a corresponding FXS VC module at the remote Megaplex, for connection to the remote extension. When operating in PCM mode, also supports battery polarity reversal for wink-start signaling and 12/16 kHz metering pulse detection for public payphones.

The following signaling transfer modes are selectable for VC-4, VC-8 and VC-16 modules:

- Channel Associated Signaling (CAS) transmitted in Timeslot 16, compatible with ITU-T Rec. G.704 (available with E1 links only);
- Inband "Robbed Bit Multiframe" (RBMF) signaling transfer (available with T1 links only). This method is compatible with ITU-T Rec. G.704 and AT&T Pub. 43801, and is generally used with μ -law companding;
- Inband "Robbed Bit Frame" (RBF) signaling transfer. This method, applicable in VC-4A and VC-8A modules, is useful for networks not supporting signaling switching
- No signaling – channel signaling is not transferred.

To provide feed and ringing signal generation voltages, FXS modules require a nominal -48 VDC (-20 to -54 VDC) source. This power can be provided either from an appropriate DC-powered chassis, or from an external Ringer power supply standalone unit or module for AC-powered chassis, in accordance with the number of module ports. VC-4/FXS, VC-4A/FXS VC-8/FXS/RJ and VC-8A/FXS modules support -24 VDC as well. A special version of VC-16/FXS can be ordered for operating with -24 VDC. (For more information, refer to *Ordering* and to a separate RAD's Ringers family data sheet). The feed and ring generation voltages are distributed to the modules via the internal voltage bus of the chassis.

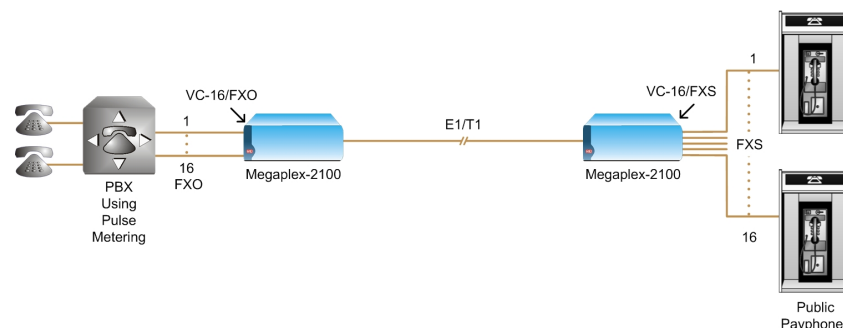

Figure 3. VC-16/FXS and VC-16/FXO Featuring Pulse Metering for Connection to Public Payphones, and Battery Polarity Reversal for Wink-start Signaling

VC-4/4A, VC-8/8A, VC-16

4/8/16-Channel PCM and ADPCM Voice Modules

Gain control is user-selectable for both the receive and transmit direction, enabling easy installation in all environments. A special 4-wire version with enhanced gain control is available for the VC-16/E&M module (see *Ordering*).

All operating parameters are configurable via the management system for both the local and remote modules.

Diagnostic features include loopbacks towards the local user equipment and towards the remote user equipment. Test tone injection of 1 kHz, 0 dBm0 towards the remote or local equipment is also available.

Table 2. Power Consumption (in Watt) from Megaplex Power Supply (without -48 VDC)

Module vs Interface Type	FXS	FXO	E&M
VC-4	2.5	1.9	2.8
VC-4A	3.3	2.7	3.6
VC-8	2.8	2.0	3.4
VC-8A	3.7	2.8	4.2
VC-16	4.7	2.5	5.2

Table 1. Transmit and Receive Levels for Various Interfaces

Module Interface	Transmit [dbm]		Receive [dbm]	
	min	max	min	max
E&M regular	-8	+5	-17	+2
E&M 4W regular	-10	+5	-17	+2
E&M 4W enhanced*	-17	+5	-17	+9
FXS	-5	+5	-17	+1
FXO	-3.5	+5	-17	+1

*Supported in Megaplex-2100/2104 only

Table 3. VC Module Connectors

Module	E&M Interface	FXO/FXS Interface
VC-4, VC-4A	RJ-45 connector per channel	RJ-12 connector per channel
VC-8	68-pin female SCSI connector for all channels	1 x 50-pin female TELCO connector for all channels
VC-8/RJ	-	RJ-12 connector per channel
VC-8A	68-pin female SCSI connector for all channels	RJ-12 connector per channel
VC-16	2 x 68-pin female SCSI connectors, one per group of 8	1 x 50-pin female TELCO connector for all channels

Specifications

Number of Voice Channels

VC-16: 16

VC-8, VC-8A: 8

VC-4, VC-4A: 4

Voice Encoding Technique

PCM: per ITU-T G.711 and AT&T

Pub. 43801, μ -law or A-law

ADPCM: per ITU-T G.726 and G.727,

μ -law or A-law

Bandwidth Requirement

PCM: 64 kbps (one timeslot) per enabled channel

ADPCM:

- 32 kbps per enabled channel (one timeslot per pair of channels) as per G.726 and G.727
- 24 kbps per enabled channel (one timeslot per pair of channels) as per G.727 (when using RBF or RBMF inband signaling)

Analog Interface

Line type:

- E&M: 4-wire or 2-wire (soft-selectable)
- FXS, FXO: 2-wire
- ITU-T standard: G.712

Connectors: see *Table 3*

Analog Parameters

Nominal level: 0 dBm

Nominal impedance: 600 Ω

Return loss (ERL) at 300 to 3400 Hz:
better than 20 dB

Frequency response (Ref:1020 Hz):

- ± 0.5 dB at 300 to 3000 Hz
- ± 1.1 dB at 250 to 3400 Hz

Level adjustment (soft-selectable):

see *Table 1*.

Steps: 0.5 dB (± 0.15 dB), nominal

Signal to total distortion (G.712):

- -30 to 0 dBm0: better than 33 dB
- -45 to +3 dBm0: better than 22 dB

Idle channel noise: better than -65 dBm0
(+25 dBnc)

Transformer isolation: 1500 VRMS

Adaptive Echo Canceller

Supports delays of up to 4 msec per channel, as per G.168 (VC-4A, VC-8A only)

Power Consumption

See *Table 2*

E&M INTERFACE

Signaling Method (selectable)

EIA RS-464 Type I;

EIA RS-464 Types II, III, and

V (British Telecom SSDC5) using -12 VDC in place of -48 VDC

Note: For full support of Types II, III, and V (SSDC5) signaling standards, -48 VDC power supply is required.

Pulse Dial Distortion

± 2 msec max

FXS INTERFACE

Signaling Methods

PCM: EIA RS-464 loop-start or wink-start

ADPCM: EIA RS-464 loop-start

On-Hook/Off-Hook Threshold

(where $V_{in} = -20$ to -54 VDC)

3V to 80% V_{in} between Tip and Ring at Off-Hook state,

Higher than 83% V_{in} between Tip and Ring at On-Hook state

Feed Current

23 mA ($\pm 10\%$) per active channel

Ringer

54 VRMS, 22 Hz ($\pm 10\%$); Overload protected, 1 second ON, 3 seconds OFF

Metering Pulse Generation

Output frequency: 12 or 16 kHz (± 2 Hz), selectable

Output level: 1.7 VRMS

Note: Metering pulse generation is not available in the ADPCM mode.

Reverse Polarity Pulse Distortion

6 msec max

-48 VDC (nominal) Current

Consumption

30 mA ($\pm 10\%$) per active channel (thus a full VC-16/FXS module consumes 480 mA; a full VC-8/FXS consumes 240 mA)

Table 4. Megaplex Voice Modules

	VC-4/8/16	VC-4A/8A	VC-16A	VC-4/OMNI	VC-6	VC-6A	VC-6/LB, VC-6/4LB
Number of ports	4/8/16	4/8	16	4	6	6	4/6
FXS	✓	✓			✓	✓	
FXO	✓	✓			✓	✓	
E&M	✓	✓		✓	✓	✓	
Local battery							✓
Omnibus				✓			
Polarity reversal & metering	✓	✓				✓	
ADPCM		✓	✓			✓	
Supported by Megaplex-4100	✓	✓					

VC-4/4A, VC-8/8A, VC-16

4/8/16-Channel PCM and ADPCM Voice Modules

RAD Ringers Support

Ringer-2100R: up to 40 channels
 Ringer-2000: up to 100 channels
 Ringer-2200N: up to 200 channels

FXO INTERFACE**Signaling Methods**

PCM: EIA RS-464 loop-start or wink-start
 ADPCM: EIA RS-464 loop-start

DC Impedance

Off-Hook:
 100Ω at 100 mA feed,
 230Ω at 25 mA feed
 On-Hook: above 1 MΩ

Ring Detector

20 kΩ @ 20 Hz, 70 VRMS
 Detection: >20 VRMS, 17–25 Hz
 No detection: <5 VRMS

Metering Pulse Detection Frequency

12 or 16 kHz (±200 Hz), soft-selectable

Note: Metering pulse detection is not available in the ADPCM mode.

Reverse Polarity Pulse Distortion

6 msec max

GENERAL**End-to-End Signaling**

T1 links:

- Robbed Bit Multiframe signaling: 667 samples per second with D4; 333 samples per second with ESF
- Robbed Bit Frame signaling

E1 links:

Channel Associated Signaling per ITU-T G.704 para. 3.3.3.2

Diagnostics

Local digital loopback for each channel, towards the local user equipment

Note: When working in the ADPCM mode, the local digital loopback towards the local user equipment is performed for each pair of consecutive channels (1-2, 3-4, etc.)

Remote analog loopback for each channel, towards the remote user equipment

1 kHz, 0 dBm0 test tone inject for each channel, towards the remote user equipment

1 kHz, 0 dBm0 backward test tone inject for each channel, towards the local user equipment

Ordering

MP-2100M-VC-4/#
 4-Channel PCM Voice Module

MP-2100M-VC-8/#
 8-Channel PCM Voice Module

MP-2100M-VC-16/#
 16-Channel PCM Voice Module

MP-2100M-VC-4A/#
 4-Channel ADPCM Voice Module

MP-2100M-VC-8A/#
 8-Channel ADPCM Voice Module

Legend

Interface type:

E&M	E&M
E&M/POS	E&M-type with positive signaling (for VC-16 and VC-8)
E&M/EXT	E&M-type operating at -48 VDC
E&M/4WIRE	E&M-type with enhanced gain levels
FXS	FXS with Telco connector (for VC-16, VC-8, VC-4, VC-4A)
FXS/RJ	FXS with RJ-12 connectors (for VC-8, VC-8A)
FXS/24VDC	FXS operating with -24 VDC (for VC-16 only*)

FXO	FXO with Telco connector (for VC-16 VC-8, VC-4, VC-4A)
FXO/RJ	FXO with RJ-12 connectors (for VC-8, VC-8A)

**Note: VC-4/FXS, VC-4A/FXS, VC-8/FXS/RJ and VC-8A/FXS modules support both -24 and -48 VDC.*

OPTIONAL ACCESSORIES

Octopus cables for splitting the high-density module (VC-8 and VC-16) connector(s) into separate channels with RJ-12/RJ-45 connectors, for direct connection to user equipment. Cable lengths are 2m (6 ft):

CBL-VC16/FXSO

Cable with 16 x RJ-12 connectors, for splitting the VC-16/FXS or VC-16/FXO single 50-pin Telco connector

CBL-VC8/FXSO

Cable with 8 x RJ-12 connectors, for splitting the VC-8/FXS or VC-8/FXO single 50-pin Telco connector

CBL-KVF8/E&M

Cable with 8 x RJ-45 connectors, for splitting a single VC-8/E&M or VC-16/E&M 68-pin SCSI connector

When ordering FXS or E&M modules, a **RINGER** may be required (see Ringer data sheet for ordering)

Note: FXS modules require a -48 VDC (nominal) source for feed and ring voltages. This power can be provided by a Ringer-2000/2200N unit or Ringer-2100R module. E&M applications may also require -48 VDC. -48 VDC-powered chassis, or AC-powered MP-2104 chassis with built-in ringer option, do not require an additional Ringer.

International Headquarters
 24 Raoul Wallenberg Street
 Tel Aviv 69719, Israel
 Tel. 972-3-6458181
 Fax 972-3-6498250, 6474436
 E-mail market@rad.com

North America Headquarters
 900 Corporate Drive
 Mahwah, NJ 07430, USA
 Tel. 201-5291100
 Toll free 1-800-4447234
 Fax 201-5295777
 E-mail market@radusa.com

www.rad.com



data communications

The Access Company