

FCD-155

STM-1/OC-3 Terminal Multiplexer

Transports LAN and TDM traffic over SDH/SONET networks



- STM-1/OC-3 PDH/Ethernet terminal multiplexer grooms LAN and legacy (TDM) traffic over SDH/SONET networks
- 10/100BaseT and GbE (Gigabit) Ethernet interfaces support VLAN and point-to-multipoint switching
- Ethernet traffic maps to one VC-3/VC-4/STS-1, up to 3 VC-3/STS-1, up to 63 VC-12 or 84 VT-1.5
- PDH interface supports 4 or 8 × E1/T1 (G.703) or a single E3/T3 link
- Channelized STM-1/OC-3 main link with fiber interface

FCD-155 is an STM-1/OC-3 SDH terminal multiplexer that transports LAN and traditional (TDM) traffic over SDH/SONET networks. When bandwidth granularity of the Ethernet channel is configured to 2 Mbps (VC-12) or 1.5 Mbps (VT-1.5), FCD-155 utilizes the SDH/SONET infrastructure for cost-effective connectivity.

Optional PDH interfaces include:

- 4- or 8-port E1 or T1 interfaces
- Single-port E3/T3 interface

Optional Ethernet interface configurations include:

- 2-port bridging 10/100BaseT interface
- 6-port 10/100BaseT interface (two bridging and four transparent ports)

Single-port Ethernet interface with 2-port bridging 10/100BaseT and 10/100/1000BaseT (RJ-45) or 1000BaseSX (SFP interface).



FCD-155

STM-1/OC-3 Terminal Multiplexer

NETWORK INTERFACE

The STM-1/OC-3 interfaces are user-configurable and provide a high-quality and high-availability link as well as performance monitoring of the traffic path.

The STM-1/OC-3 link is supplied with an SFP socket (see *Ordering*). It is strongly recommended to order this device with **original RAD SFPs installed**. This will ensure that prior to shipping, RAD has performed comprehensive functional quality tests on the entire assembled unit, including the SFP devices. RAD cannot guarantee full compliance to product specifications for units using non-RAD SFPs.

The user can define the following SDH/SONET clock sources:

- Internal
- Recovered from the STM-1/OC-3 interface, including automatic selection based on SSM (Synchronization Status Messaging)
- External E1

FCD-155 supports an optional 1+1 link protection mechanism (unidirectional MSP/APS) and SNCP path protection.

Maintenance capabilities include user-activated local loopbacks and remote loopbacks on the STM-1/OC-3 main link and PDH tributaries.

LAN INTERFACE

The 2-port 10/100BaseT or single-port Gigabit Ethernet interfaces include a built-in Ethernet bridge that supports VLAN according to IEEE 802.1Q and 802.1p.

The 4-port transparent LAN extension, without bridge functionality, creates total separation between customers for security. The maximum frame length is 2 kb.

The 10/100BaseT LAN interface supports autonegotiation for plug-and-play Ethernet connectivity and complies to IEEE 802.3/Ethernet V.2 standards. The interface also supports VLAN stacking.

An optional Gigabit Ethernet port enables connection of one LAN port to eight virtual groups. This option provides LAN extension over SDH/SONET networks with bridge functionality. The maximum frame length is 2 kb.

Ethernet traffic is mapped into SDH/SONET containers using VCAT and encapsulated with:

- Generic Framing Procedure (ITU-T G.7041, ANSI T1-105.02), framed mode
- Link Access Procedure for SDH/SONET (LAPS) protocols following draft recommendation ITU-T X.85/X.86.

Each user's Ethernet traffic can be mapped into SDH/SONET virtual containers in any of the following ways:

- Up to 63 x VC-12, or 84 x VT-1.5
- 3 x VC-3/STS-1
- 1 x VC-4.

Ethernet traffic can be switched to different bundles of virtually concatenated VCs (up to 8 bundles) according to a predefined group.

Link Capacity Adjustment Scheme (LCAS) is supported in compliance with the G.7042 standard, which allocates bandwidth according to Ethernet traffic.

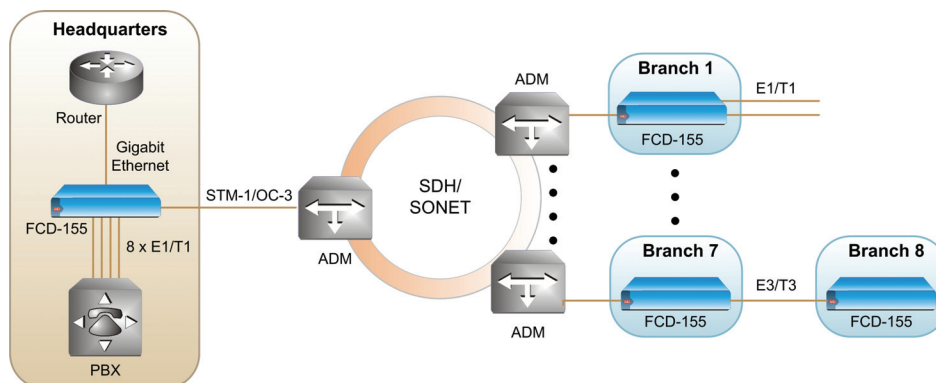

Figure 1. ADM Application in a Corporate Environment

SDH/SONET media can transport basic Ethernet packets of up to 1536 bytes enabling connection to MPLS networks.

The Ethernet interfaces allow interconnection of SAN (Storage Area Networks) devices with Ethernet packets up to 2 kb.

Spanning Tree Protocol (STP) and Rapid Spanning Tree Protocol (RSTP) support Layer 2 ring applications.

TDM INTERFACE

FCD-155 has an optional interface module containing 4 or 8 E1/T1 balanced interface ports that transfer data transparently in compliance with the G.703 standard. The unbalanced E1 interface is software selectable on the 8-port version. The 4-port version is jumper-selectable and requires an adapter cable (see *Ordering*).

An optional E3/T3 port supports unframed E3/T3 links over SDH/SONET.

TDM traffic is mapped into SDH/SONET VC-12/VC-11/VC-3 or SONET VT1.5/STS-1 containers that can be placed anywhere within the STM-1/OC-3 bandwidth.

MANAGEMENT

Remote units can be managed in any of the following ways:

- Via DCC using IP tunneling over OSI DCN based on ITU-T G.7712
- IP/PPP over DCC protocol
- Via dedicated virtual group containing at least one VC-12/VT-1.5 channel
- Inside user traffic in a virtual group separated by the GFP Channel ID or VLAN tag
- Out-of-band, via direct connection to one of the LAN ports.

Status and diagnostic information is defined, configured, and monitored using one of the following methods:

- ASCII terminal connected to the V.24/RS-232 control port
- Telnet host via management platform or LAN port
- Network management station running RADview, the RAD SNMP network management application
- TFTP applications to update software and upload/download remote configurations
- ConfiguRAD via Web browser.

DIAGNOSTICS

FCD-155 has comprehensive diagnostic capabilities, including:

- Ethernet and SDH/SONET link monitoring
- Real-time alarms that alert the user of fault conditions. Alarms are reported to the management station and simultaneously relayed through a dry contact port.

GENERAL

An AC or DC power supply is provided with an alarm-activated fan for forced-air cooling.

FCD-155 is a compact standalone unit. One or two units can be installed side-by-side in a 19-inch rack using the optional rack-mount adaptor kit. One unit can be mounted on the wall using the optional wall-mount adapter kit (see *Ordering*).

SPECIFICATIONS

STM-1/OC-3 MAIN LINK (NETWORK)

Number of Ports

1 (second link available for redundancy)

Bit Rate

155.52 Mbps \pm 20 ppm

SFP Socket

Characteristics: See *Table 1*

SPF options: See *Ordering*

Timing

Internal clock

Recovered from the STM-1/OC-3 interface

External clock from PDH tributary

Compliance

SDH: ITU-T G.957

SONET: GR-253-core

Framing

SDH: ITU-T G.707, G.708, G.709

SONET: ANSI T1.105-1995, GR-253-core

Line Code

NRZ

LAN INTERFACE (OPTION)

Port Types

2 or 6 10/100BaseT ports

1 GbE

Compatibility

Relevant sections of IEEE 802.3u, 802.3x, 802.1D and 802.1Q

LAN Table

2,048 MAC addresses (2U) and 8,182 (GbE) with selectable automatic aging time

Data Rate

10BaseT: 10 Mbps

100BaseT: 100 Mbps

1000BaseT: 1000Mbps (Gigabit Ethernet)

Autonegotiation

Connectors (per port)

RJ-45, shielded

SFP socket (for transceivers, see *Ordering*)

E1/T1 PDH INTERFACE (OPTION)

Number of Ports

4 E1, 4 T1, 8E1, or 8 T1

Compatibility

ITU-T Rec. G.703, unframed

Nominal Data Rate

E1: 2.048 Mbps

T1: 1.554 Mbps

Line Code

E1: HDB3

T1: B8ZS

Impedance

E1: 120 Ω balanced or 75 Ω unbalanced

T1: 100 Ω balanced

Table 1. SFP Interface Characteristics

	Transceiver	Wavelength [nm]	Fiber Type [μ m]	Transmitter Type	Connector Type	Input Power [dBm]		Output Power [dBm]		Typical Max. Range	
						(min)	(max)	(min)	(max)	[km]	[miles]
STM-1/OC-3 Uplink	SFP-1	1310	62.5/125 multimode	VCSEL	LC	-30	-14	-20	-14	2	1.2
	SFP-2	1310	9/125 single mode	Laser	LC	-28	-8	-15	-8	15	9.3
	SFP-3	1310	9/125 single mode	Laser	LC	-34	-10	-5	0	40	24.8
	SFP-4	1550	9/125 single mode	Laser	LC	-34	-10	-5	0	80	49.7
	SFP-11	Copper Uplink	Coaxial cable 75 Ω	-	Mini-BNC	-	-	-	-	0.135*	0.08*
	SFP-18a	Tx - 1310 Rx - 1550	9/125 single mode (single fiber)	Laser (WDM)	LC	-28	-8	-5	0	40	24.8
	SFP-18b	Tx - 1550 Rx - 1310	9/125 single mode (single fiber)	Laser (WDM)	LC	-28	-8	-5	0	40	24.8
	SFP-19a	Tx - 1490 Rx - 1570	9/125 single mode (single fiber)	Laser (WDM)	LC	-30	-8	0	+5	80	49.7
	SFP-19b	Tx - 1570 Rx - 1490	9/125 single mode (single fiber)	Laser (WDM)	LC	-30	-8	0	+5	80	49.7
	GbE User Port	SFP-5	850	50/125 multimode	VCSEL	LC	-17	0	-9.5	0	0.55
SFP-6		1310	9/125 single mode	Laser	LC	-20	-3	-9.5	-3	10	6.2
SFP-7		1550	9/125 single mode	Laser	LC	-22	-3	0	+5	80	49.7
SFP-8D		1310	9/125 single mode	Laser	LC	-21	-3	0	-4	40	24.8

* Using RG59 B/U.

FCD-155

STM-1/OC-3 Terminal Multiplexer

Maximum Line Attenuation

36 dB (LTU mode)
12 dB (DSU mode)

Timing

Source clock is recovered from the receive signal coming from the remote E1/T1 side

Locked to the SDH/SONET interface clock

Connectors

4-ports: RJ-45, shielded
8-ports: 44-pin, D-type, female

E3/T3 PDH INTERFACE (OPTION)

Number of Ports

1

Compatibility

ITU-T Rec. G.703, unframed

Data Rate

E3: 34.368 Mbps
T3: 44.736 Mbps

Framing

Unframed

Line Code

E3: HDB3
T3: B3ZS

Line Impedance

75Ω

Connector

Two BNC female

Timing

Source clock is recovered from the receive signal from the remote E3/T3 side

Locked to the SDH/SONET interface clock

MANAGEMENT PORTS

CONTROL Port

Interface: V.24/RS-232

Connector: 9-pin D-type, female

Format: Asynchronous

Baud rate: 0.3–115.2 kbps

Selectable word format:

7 or 8 bits, no parity, 7 bit odd or even parity

Out-of-Band Access

Single Ethernet port FCD-155 version:

MNG ETH port

Other FCD-155 versions:

ETH 1 and ETH 2 ports (through internal Ethernet switch)

INDICATORS

General

PWR (green) – Power

TST (yellow) – Test

MAJ ALM (red) – Major alarm

MIN ALM (red) – Minor alarm

LOC SYNC LOSS (red) – Local loss of synchronization on the STM-1/OC-3 links

REM SYNC LOSS (red) – Remote loss of synchronization on the STM-1/OC-3 links

ETH, MNG, GbE (per port)

LINK (green) – LAN link integrity

ACT (yellow) – LAN data activity

E1/T1 PDH Interface (per port)

SIG LOSS (red) – E1 link signal loss

AIS (red) – AIS on E1 link

E3/T3 PDH Interface

SIG LOSS (red) – E3/T3 link signal loss

STM-1/OC-3 Main Links

SIG LOSS (red) – STM-1/OC-3 link signal loss

ON LINE (green) – STM-1/OC-3 link is active (indicator is on) or on standby (indicator is blinking)

GENERAL

Power

AC: 100 to 240 VAC ±10%,
50 to 60 Hz

DC: –48 VDC (–40 to –72 VDC)

Power Consumption

30W

Alarms

Last 100 alarms are time-stamped, stored, and available for retrieval

Alarm Relay Port

Operation: normally open,

normally closed, using different pins

Connector: 9-pin, D-type, female

Physical

Height: 4.4 cm (1.7 in)

Width: 21.5 cm (8.5 in)

Depth: 30.0 cm (11.8 in)

Weight: 2.4 kg (5.3 lb)

Environment

Temperature: 0°–50°C (32°–122°F)

Humidity: Up to 90%,
non-condensing

Ordering

FCD-155*/&/&/&

STM-1/OC-3 Terminal Multiplexer

Note: SFP transceivers are not included in the chassis for the uplink and/or the fiber GbE interfaces (see SFP Transceivers).

Legend

* Power supply:

AC 100 to 240 VAC

48 –48 VDC

& LAN interface:

2U 2 bridging 10/100BaseT ports

6U 2 bridging and 4 transparent
10/100BaseT ports

GE 1 10/100/1000BaseT (GbE)
port, copper interface and SFP
socket

\$ PDH interface:

4E1 4 × E1 G.703 ports

4T1 4 × T1 G.703 ports

8E1 8 × E1 G.703 ports

8T1 8 × T1 G.703 ports

E3 1 × E3 G.703 port

T3 1 × T3 G.703 port

Notes:

The 4 × E1 port option is delivered with a balanced E1 interface.

To convert the interface from balanced to unbalanced, use converter cable CBL-RJ45/2BNC/E1/X.

FCD-155-PACK1

Software key for activating
IP tunneling management option

FCD-155

STM-1/OC-3 Terminal Multiplexer

SFP TRANSCEIVERS

(For redundancy, order two SFP transceivers)

STM-1/OC-3 Uplink

- SFP-1** STM-1/OC-3, 1310 nm multimode VCSEL, LC connector
- SFP-2** STM-1/OC-3, 1310 nm single mode laser (S1.1), LC connector
- SFP-3** STM-1/OC-3, 1310 nm, single mode laser, long haul (L1.1), LC connector
- SFP-4** STM-1/OC-3, 1550 nm single mode laser, long haul (L1.2), LC connector
- SFP-11** STM-1/OC-3, electrical interface, mini-BNC coaxial connector
- SFP-18a** STM-1/OC-3, Tx - 1310, Rx - 1550, 9/125 single mode (single fiber), laser (WDM), LC connector
- SFP-18b** STM-1/OC-3, Tx - 1550, Rx - 1310, 9/125 single mode (single fiber), laser (WDM), LC connector
- SFP-19a** STM-1/OC-3, Tx - 1490, Rx - 1570, 9/125 single mode (single fiber), laser (WDM), LC connector
- SFP-19b** STM-1/OC-3, Tx - 1570, Rx - 1490, 9/125 single mode (single fiber), laser (WDM), LC connector

GbE User

- SFP-5** GbE, 850 nm multimode VCSEL
- SFP-6** GbE, 1310 nm single mode laser (LX-SM)
- SFP-7** GbE, 1550 nm single mode laser, long haul LX-H (ZX)
- SFP-8D** GbE, 1310 nm single mode laser, long haul (LX-H)

*Note: It is strongly recommended to order this device with **original RAD SFPs installed**. This will ensure that prior to shipping, RAD has performed comprehensive functional quality tests on the entire assembled unit, including the SFP devices. RAD cannot guarantee full compliance to product specifications for units using non-RAD SFPs.*

SUPPLIED ACCESSORIES

- AC power cord (when AC power supply is ordered)
- DC adapter plug (when DC power supply is ordered)
- CBL-DB9F-DB9M-STR**
Control port cable

OPTIONAL ACCESSORIES

CBL-RJ45/2BNC/E1/X

Cable for converting a balanced E1 interface to an unbalanced E1 interface. Contains one RJ-45 balanced connector and two unbalanced BNC coaxial connectors.

CBL-SMB-BNC/M/E

Cable for adapting two mini-BNC connectors to two full-sized BNC connectors (for SFP-11)

CBL-G703-8/^

8E1/8T1 interface cables for the DB-44 port connector (one cable required per interface):

Legend

- * Connector type:
- RJ45** splits into 8 E1/T1 balanced RJ-45 connectors
- RJ45/X** splits into 8 E1/T1 balanced RJ-45 connectors (cross-cable)
- COAX** splits into 8 pairs of E1 unbalanced BNC male connectors
- OPEN** 8 × 4 unterminated free leads 2m (6.6 ft)

RM-35/@

Hardware kit for mounting one or two units in a 19-inch rack

Legend

- @ Rack mount kit type:
- P1** Mounting one unit
- P2** Mounting two units

WM-35

Hardware for mounting one unit on the wall

International Headquarters

24 Raoul Wallenberg Street
Tel Aviv 69719, Israel
Tel. 972-3-6458181
Fax 972-3-6498250, 6474436
E-mail market@rad.com

North America Headquarters

900 Corporate Drive
Mahwah, NJ 07430, USA
Tel. 201-5291100
Toll free 1-800-4447234
Fax 201-5295777
E-mail market@radusa.com