

# Optimux-45L

## Multiple E1 or T1 to T3 Multiplexer



### Any Traffic Over Fiber

- Multiplexes up to 28 T1 or 21 E1 channels into a single 45 Mbps data stream
- Supports a combination of T1 and E1 channels
- Transmission over coax or fiber optic cable
- Range up to 110 km (68 miles)



Optimux-45L provides a simple, flexible and cost-effective solution for transporting multiple T1 and E1 signals at distances of up to 110 km (68 miles).

Optimux-45L integrates up to 28 T1, 21 E1, or any combination of T1 and E1 channels, over a single 45 Mbps data stream. This provides an easily configurable solution, flexible enough to meet the specific requirements of a broad range of applications.

Two Optimux-45L units can be connected over a single fiber link, using either WDM (Wavelength Division Multiplexing) or another bidirectional technology, thus saving on fiber usage.

Various optical interfaces are available for the fiber main link:

- 850 nm VCSEL for multimode fiber
- 1310 nm LED for multimode fiber
- 1310 and 1550 nm laser for extended range over single mode fiber
- 1310 and 1550 nm laser for single fiber WDM operation
- 1310 nm laser for single fiber/single wavelength operation



# Optimux-45L

## Multiple E1 or T1 to T3 Multiplexer

Critical hardware components can be backed-up if necessary. This ensures that any single point of failure will not disrupt the entire system. An optional hot-swappable second main link provides backup, using automatic switchover upon link failure. An optional second power supply provides power redundancy for fail-safe operation.

Optimux-45L is provided with two 64-pin Telco connectors for balanced or unbalanced tributary ports.

Optimux-45L transmits the clock of each of the E1/T1 channels independently.

Setup, control and diagnostics can be performed using an ASCII terminal connected via the DB-9 control port. Alternatively, these functions can be performed using a Telnet or a RADview application, connected to the dedicated Ethernet management port.

Optimux-45L is interoperable with RAD's Optimux-45, FOM-T3 and FOMi-T3 devices.

RADview, RAD's SNMP management application software provides a user-friendly GUI for Optimux-45L configuration, monitoring and management. RADview applications are available for either Windows or UNIX-based HP OpenView environments.

To facilitate system diagnostics, Optimux-45L features LED status indicators, AIS alarm generation and recognition, dry contact closure upon link failure, and diagnostic loopbacks on the E1/T1 and T3 links.

Optimux-45L is available as a compact 1U-high unit that can be mounted in a 19-inch (ANSI) or ETSI rack.

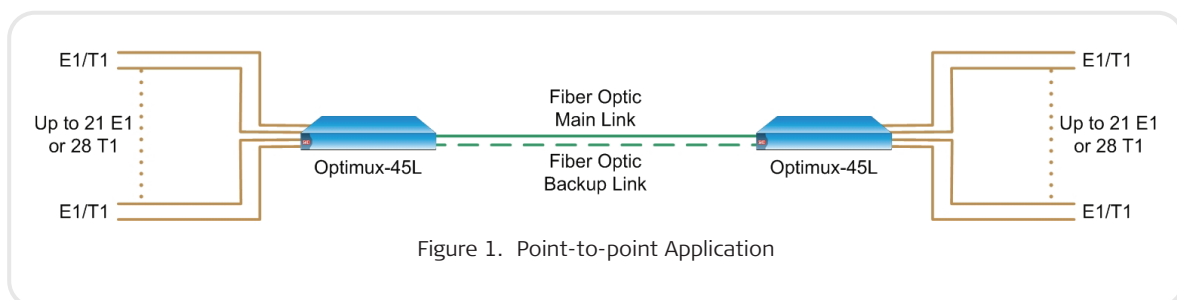

## Specifications

### MAIN and BACKUP LINKS

#### Data Rate (T3)

44.736 Mbps

#### Redundancy

Optional second link

#### Optical Interface Characteristics

See *Table 2*

### ELECTRICAL INTERFACE

#### Standards

G.703, G.824

#### Line Code

B3ZS

#### Impedance

75Ω, unbalanced

#### Range

According to ITU-T Rec. G.703

#### Connectors

Two shielded BNC

### TRIBUTARY CHANNELS

#### Interface Type

E1: Balanced or unbalanced

T1: Balanced

#### Number of Channels

28 T1, or 21 E1

#### Standards

G.703, G.823, G.824

#### Data Rate

E1: 2.048 Mbps

T1: 1.544 Mbps

#### Line Code

E1: HDB3 or AMI

T1: B8ZS or AMI

#### Impedance

E1: 120Ω, balanced

75Ω, unbalanced

T1: 100Ω, unbalanced

#### Range

According to ITU-T Rec. G.703

### Jitter

E1: According to ITU-T G.823

T1: According to ITU-T Rec. G.703

### Connectors

Two Telco 64-pin for all channels

### SUPERVISORY and MANAGEMENT PORTS

#### Control Port

Interface: RS-232

Connector: DB-9

#### Ethernet Port

Interface: 10BaseT

Connector: RJ-45

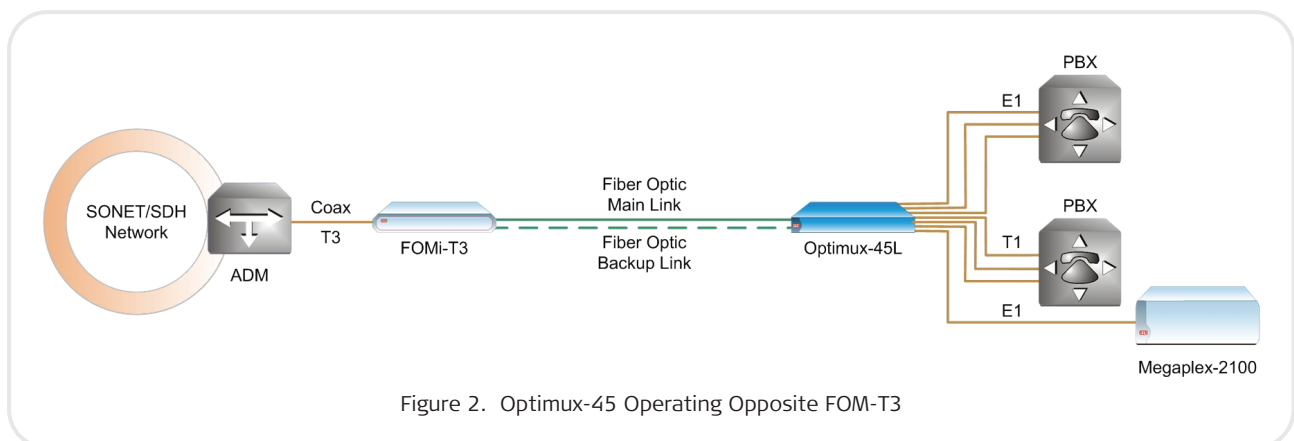

Figure 2. Optimux-45 Operating Opposite FOM-T3

**GENERAL****Alarm Relay**

DB-9 connector with dry relay contacts, for major and minor alarms

**Station Clock**

Optional external station clock input, using RJ-45 connector via optional station clock module

**Monitoring**

Built-in monitoring capabilities of each one of the tributary input channels

**Power**

Number of power supplies: one or two (power sharing and redundancy)

AC Power Module 100 to 240 VAC, 50/60 Hz; 70 VA

DC Power Module:

-48 VDC (-36 to -72 VDC), 1.2A; 45W  
24 VDC (±10%); 2.2A; 45W

**Maximum Power Consumption**

24W

**Physical**

Height: 4.4 cm (1.7 in)

Width: 44 cm (17 in)

Depth: 24 cm (9.4 in)

Weight: 3.8 kg (8.4 lb)

**Environment**

Temperature:

0–55°C (32–131°F)

Humidity: Up to 90%, non-condensing

Table 1. Optimux Comparison Chart

| Feature          | Optimux-4E1/4T1                  | Optimux-34        | Optimux-XLT1 | Optimux-45/45L            | Optimux-1551               | Optimux-1553    |
|------------------|----------------------------------|-------------------|--------------|---------------------------|----------------------------|-----------------|
| Uplink           | E1/T1                            | E3                | T1           | T3                        | STM-1/OC-3                 | STM-1/OC-3      |
| Bandwidth (Mbps) | 8/6                              | 34                | 25           | 45                        | 155                        | 155             |
| Number of trunks | 4 E1<br>4 T1                     | 16 E1<br>16 T1    | 16 T1        | 21 E1<br>28 T1            | 21/42/63 E1<br>28/56/84 T1 | 3 E3<br>3 T3    |
| Ethernet support | -                                | ✓                 | ✓            | -                         | -                          | -               |
| Special features | Redundant, hot-swappable uplinks | SFP-based uplinks | Modular      | Ring support (Optimux-45) | Full redundancy            | Full redundancy |

# Optimux-45L

## Multiple E1 or T1 to T3 Multiplexer

Table 1. Main Link Interface Options

| Module Name<br>(Ordering Option)             | Wavelength           | Fiber Type                       | Transmitter Type  | Power Coupled into Fiber | Receiver Sensitivity | Typical Max. Range |         | Connector Type |
|--|----------------------|----------------------------------|-------------------|--------------------------|----------------------|--------------------|---------|----------------|
|  | [nm]                 | [ $\mu$ m]                       |                   | [dBm]                    | [dBm]                | [km]               | [miles] |                |
| OP-M/CX/155                                  | -                    | Copper cable                     | -                 | -                        | -                    | 135m               | 443 ft  | Coax interface |
| OP-M/SC/85L<br>OP-M/FC/85L<br>OP-M/ST/85L    | 850                  | 62.5/125 multimode               | Laser (VCSEL)     | -14 to -20               | -26                  | 2.0                | 1.2     | SC, FC, ST     |
| OP-M/SC/13M<br>OP-M/ST/13M                   | 1310                 | 62.5/125 multimode               | LED               | -14 to -20               | -31                  | 2.0                | 1.2     | SC, ST         |
| OP-M/SC/13L<br>OP-M/FC/13L<br>OP-M/ST/13L    | 1310                 | 9/125 single mode                | Laser             | -8 to -15                | -31                  | 20                 | 12.4    | SC, FC, ST     |
| OP-M/SC/15L<br>OP-M/FC/15L<br>OP-M/ST/15L    | 1550                 | 9/125 single mode                | Laser             | -8 to -15                | -31                  | 20                 | 12.4    | SC, FC, ST     |
| OP-M/SC/13LH<br>OP-M/FC/13LH<br>OP-M/ST/13LH | 1310                 | 9/125 single mode                | Laser (long haul) | 0 to -5                  | -34                  | 40                 | 24.8    | SC, FC, ST     |
| OP-M/SC/15LH<br>OP-M/FC/15LH<br>OP-M/ST/15LH | 1550                 | 9/125 single mode                | Laser (long haul) | 0 to -5                  | -34                  | 80                 | 49.7    | SC, FC, ST     |
| OP-M/SC/SF1                                  | Tx: 1310<br>Rx: 1550 | 9/125 single mode (single fiber) | Laser WDM         | -8 to -15                | -29                  | 20                 | 12.4    | SC             |
| OP-M/SC/SF2                                  | Tx: 1550<br>Rx: 1310 | 9/125 single mode (single fiber) | Laser WDM         | -8 to -15                | -29                  | 20                 | 12.4    | SC             |
| OP-M/SC/SF3                                  | Tx/Rx: 1310          | 9/125 single mode (single fiber) | Laser (SF3)       | -8 to -15                | -27                  | 20                 | 12.4    | SC/APC         |

- Notes:**
- For copper cables (coax interface), a range of 135m is attainable when using RG-59 B/U (at 78 MHz, in accordance with the square root frequency law).
  - The ranges specified above were calculated according to the following typical attenuation rates (with a 3 dB margin):
    - 3.5 dB/km for 850 nm multimode
    - 0.4 dB/km for 1310 nm single mode
    - 0.25 dB/km for 1550 nm single mode

## Optimux-45L

## Multiple E1 or T1 to T3 Multiplexer

## Ordering

OP-45L/ε/~/?/#+/^

## Legend

- ε Channel interface:  
 B balanced E1/T1 interface  
 U unbalanced E1 interface
- ~ Power supply:  
 AC 100 to 240 VAC  
 48 -48 VDC  
 24 24 VDC
- ! Redundant power supply:  
 R second (redundant) power supply (identical to the first power supply)
- ? Station clock:  
 STC optional station clock
- # Main link connector type:  
 ST ST type fiber  
 SC SC type fiber  
 FC FC type fiber  
 CX electrical interface with coaxial BNC connectors

**Note:** For single fiber, single wavelength connection (SF3 interface module), only SC type connectors are available. For 1310 nm multimode LED option, only SC and ST type connectors are available.

- + Optical wavelength and transmitter type (not relevant with CX option):  
 85L 850 nm, multimode VCSEL  
 13 1310 nm, multimode LED  
 13L 1310 nm, single mode, laser diode  
 15L 1550 nm, single mode, laser diode  
 13LH 1310 nm, single mode, long haul laser diode  
 15LH 1550 nm, single mode, long haul laser diode  
 SF1 single fiber for transmit 1310 nm, receive 1550 nm

- SF2 single fiber for transmit 1550 nm, receive 1310 nm  
 SF3 single fiber for 1310 nm single wavelength laser  
 ^ Second main link:  
 D Optional second main link (identical to the first main link)

**Note:** For single-fiber applications, a device with the SF-1 connector should always be used opposite the device with the SF-2 connector, and vice versa. The SF-3 connector can be used on both sides of the link.

## OP-45-M/#/+

Additional main link module (specify if the second main link module is different from the first main link module)

## SUPPLIED ACCESSORIES

AC power cord (when AC power supply is ordered)

DC adapter plug (when DC power supply is ordered)

## RM-34

Hardware kit for mounting one Optimux-45L unit into a 19-inch rack

## OPTIONAL ACCESSORIES

## OP-A/ADAPTOR/%

Optional patch panel interface adaptors to convert Telco into channel connectors

## Legend

- % Patch panel interface:  
 21BNC/45L patch panel with 21 BNC unbalanced E1 interfaces, includes one CBL-TELCO-TELCO/UB cable  
 28RJ patch panel with 28 RJ-45 balanced E1/T1 interfaces, includes two CBL-TELCO-TELCO/2M cables.

## CBL-TELCO-OPEN/2M

Optional adaptor cable Telco 64-pin, open ended, 2m long.

**Note:** Two Telco-Open cable sets need to be ordered to support all of the tributary channels.

## CBL-TELCO-TELCO/2M

Optional extension cable for balanced interface, Telco 64-pin to Telco 64-pin, 2m long.

## CBL-TELCO-TELCO/UB

Optional extension cable for unbalanced interface, Telco 64-pin to Telco 64-pin, 2m long

## RM-34/ETSI

Hardware kit for mounting one Optimux-45L unit into a 19-inch ETSI rack

## WM-34

Hardware kit for mounting one Optimux-45L unit on the wall

## International Headquarters

24 Raoul Wallenberg Street  
 Tel Aviv 69719, Israel  
 Tel. 972-3-6458181  
 Fax 972-3-6498250, 6474436  
 E-mail market@rad.com

## North America Headquarters

900 Corporate Drive  
 Mahwah, NJ 07430, USA  
 Tel. 201-5291100  
 Toll free 1-800-4447234  
 Fax 201-5295777  
 E-mail market@radusa.com

www.rad.com



data communications

The Access Company