

Optimux-34

16 E1, Ethernet or Data over E3 or Fiber Multiplexer



Multiple E1, Ethernet,
or High-speed Data
over E3 or Fiber,
up to 110 km
(68 miles)

- Up to 16 E1 links, high-speed data, and Ethernet traffic multiplexed into one E3 copper or fiber optic link
- Interfaces available: single-mode, multimode, single-mode over single fiber, or coax
- Range of up to 110 km (68 miles)
- ITU G.703, G.742, G.751, G.823, G.955, and IEEE 802.3 compliance
- Redundancy provided by optional second modular, hot-swappable power supply and second E3 copper or fiber link



Optimux-34 provides a simple, flexible, and cost-effective solution for transporting multiple E1 links, high-speed data or Ethernet over an E3 copper or a fiber link to distances of up to 110 km (68 miles). The E3 link is available with single-mode or multimode fiber, single-mode over single fiber, or coax interfaces.

The unit provides up to 16 E1 links, some of which can be replaced by high-speed data and/or 10/100BaseT user Ethernet traffic, selectable by the user (see *Table 1*). It is designed for applications requiring the full E3 bandwidth for multiple E1 connectivity.



Optimux-34

16 E1, Ethernet or Data over E3 or Fiber Multiplexer

An optional second link provides link backup, using automatic switchover upon link failure. An optional second power supply provides power redundancy for fail-safe operation.

Optimux-34 transmits each E1 channel separately so that the clock of each E1 channel is independent.

The unit is supplied with a 10/100BaseT Ethernet user port that can be activated at any time via a software key purchased from RAD.

Various fiber optic and electrical interfaces (based on SFP transceivers) are available for both the active and the backup E3 copper or fiber links:

- Electrical via coax (SMB) connector
- 1310 nm short or long-haul laser and 1550 nm long-haul laser interfaces for extended range over single-mode fiber

- Single fiber interface using WDM technology, where the laser transmit signal is at a different wavelength from the receive signal (1310 nm and 1550 nm)
- Single fiber single wavelength interface using SC/APC connector, with a 1310 nm laser diode for single wavelength operation.

It is strongly recommended to order this device with **original RAD SFPs installed**. This will ensure that prior to shipping, RAD has performed comprehensive functional quality tests on the entire assembled unit, including the SFP devices. RAD cannot guarantee full compliance to product specifications for units using non-RAD SFPs.

The unit can be supplied with one V.35 (2 MB/sec) channel that replaces channel 16 by user activation.

An optional alarm port is available with dry relay contacts for major and minor alarms.

To ease system diagnostics, Optimux-34 features LED status indicators, AIS alarm generation, recognition, and dry contact closure upon link failure.

Management and diagnostics can be performed via:

- ASCII terminal
- Telnet
- RAD's Web-based management application
- RADview, RAD's SNMP-based management application.

Optimux-34 is available in two versions:

- 1U-high unit with balanced E1 interface, RJ-45 connectors
- 2U-high unit with unbalanced E1 interface, BNC or IEC-169/13 connectors.

Both units can be mounted in a 19-inch rack.

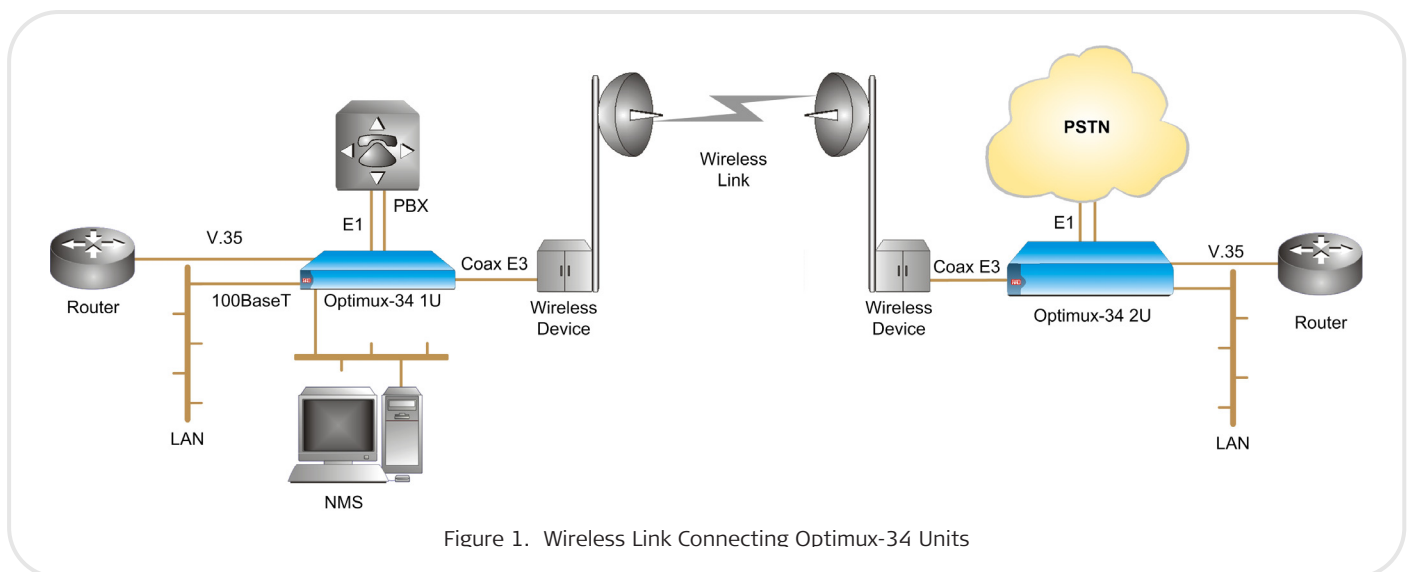

Figure 1. Wireless Link Connecting Optimux-34 Units

Specifications

E1 INTERFACE

Number of Channels
16

Line Interface
75Ω, unbalanced
120Ω, balanced

Connectors
RJ-45 for balanced
BNC or IEC-169/13 for unbalanced
in 2U unit

Note: For balanced and unbalanced channels in the same unit, order a 1U-high unit and one CBL-RJ45/BNC/E1/X adaptor cable for each pair of BNC connectors.

E3 INTERFACE (MAIN and BACKUP)

Interface Options
See *Table 2*

Electrical
Data rate: 34.368 Mbps
Line code: HDB3
Impedance: 75Ω, unbalanced
Connectors: SMB

Optical
Connectors: SFP interfaces with LC connectors or SC/APC for single wavelength single fiber

Standards
ITU G.703, G.742, G.751, G.823, G.955, IEEE 802.3

HIGH-SPEED INTERFACE

Type
V.35
Connector
DB-25 (ISO-2110 or Telebras pinout)

USER-ETH and MNG-ETH INTERFACE

Type
10/100BaseT
Connector
RJ-45

CONTROL PORT

Type
RS-232 DCE asynchronous
Connector
9-pin D-type female

ALARM PORT

Type
Dry relay contacts for major and minor alarms
Connector
9-pin D-type female

Table 1. Available E1 and Ethernet Combinations

E1 Channels	Ethernet Capacity [Mbps]
16	0
12	8
8	16
4	24
0	32

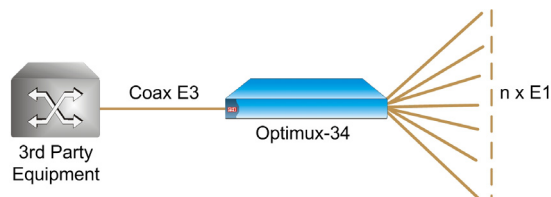

Figure 2. Fanning-out E1 Channels from Standard E3

INDICATORS

Power

OFF – Not powered
 ON (green) – Normal operation
 ON (red) – Power malfunction

System

TST (yellow) – Self-test or loop
 FLT (red) – System fault

Main Link SFP (per port)

SYNC LOSS (red) – Signal loss or frame loss detected on uplink
 AIS (yellow) – AIS detected on uplink

User Ethernet Port

LINK/ACT (lights yellow) – LAN up status
 LINK/ACT (flashes yellow) – LAN traffic transfer
 100 (green) – On: 100 Mbps operation
 100 (green) – Off: 10 Mbps operation

E1 Interfaces (per port)

SYNC LOSS (red) – Signal loss detected on E1 link
 AIS (yellow) – AIS detected on E1 link

Management Port

LINK/ACT (lights yellow) – LAN up status
 LINK/ACT (flashes yellow) – LAN traffic transfer
 100 (green) – On: 100 Mbps operation
 100 (green) – Off: 10 Mbps operation

GENERAL

Power

100–240 VAC, 50/60 Hz, -48 VDC (-40 to -72 VDC)
 24/48 VDC

Power Consumption

AC: 32 VA max
 DC: 13W max

Physical

1U-height
 Height: 4.4 cm (1.8 in)
 Width: 44.0 cm (17.0 in)
 Depth: 24.0 cm (9.0 in)
 Weight: 3.5 kg (8.0 lb)

2U-height
 Height: 8.8 cm (3.5 in)
 Width: 44.0 cm (17.0 in)
 Depth: 24.0 cm (9.0 in)
 Weight: 4.0 kg (9.0 lb)

Environment

Temperature: 0° to 50°C (32° to 122°F)
 Humidity: Up to 90%, non-condensing

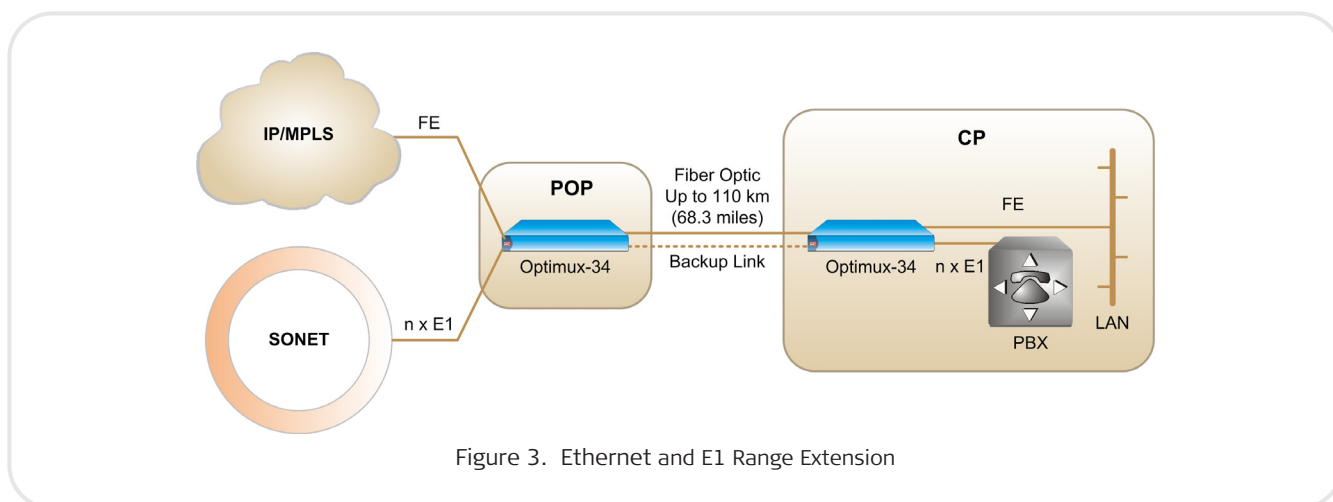

Figure 3. Ethernet and E1 Range Extension

Optimux-34

16 E1, Ethernet or Data over E3 or Fiber Multiplexer

Table 2. Main Link Interface Options

Module Name (Ordering Option)	Transmitter Type and Wavelength [nm]	Connector Type	Fiber Type	Typical Output Power [dBm]	Receiver Sensitivity [dBm]	Typical Range [km] [miles]	
SFP-12	-	SMB	Coax cable	-	-	(Per ITU-T G.703 standard)	
SFP-1	LED, 1310	LC	62.5/125 Multimode	-18	-31	6.5	4.0
SFP-2	Laser, 1310	LC	9/125 Single mode	-12	-31	38	23.6
SFP-3	Long haul laser, 1310	LC	9/125 Single mode	-2	-34	70	43.4
SFP-4	Long haul laser, 1550	LC	9/125 Single mode	-2	-34	110	68.3
SFP-10a	Laser WDM, Transmit: 1310, Receive: 1550	LC	9/125 Single mode (single fiber)	-12	-30	40	24.8
SFP-10b	Laser WDM, Transmit: 1550, Receive: 1310	LC	9/125 Single mode (single fiber)	-12	-30	40	24.8

Note: Typical ranges are calculated according to attenuation of 0.4 dB/km for 1310 nm, 0.25 dB/km for 1550 nm for single mode fiber.

Table 3. Optimux Comparison Chart

Feature	Optimux-108	Optimux-106	Optimux-34	Optimux-25	Optimux-45/45L	Optimux-1551	Optimux-1553
Uplink	Fiber Optic	Fiber Optic	E3, Fiber Optic	Fiber Optic	T3, Fiber Optic	Copper, STM-1/OC-3	Copper, STM-1/OC-3
Bandwidth (Mbps)	108	81	34	25	45	155	155
Number of trunks	4 E1	4 T1	16 E1	16 T1	21 E1 28 T1	21/42/63 E1 28/56/84 T1	3 E3 3 T3
Ethernet support	✓	✓	✓	✓	-	-	-
Special features	Redundant, hot-swappable uplinks Card version for LRS-102*	Redundant, hot-swappable uplinks Card version for LRS-102*	SFP-based uplinks	SFP-based uplinks	Ring support (Optimux-45)	Full redundancy	Full redundancy

***Note:** A central site solution is available (LRS-102 transparent modem rack)

Optimux-34

16 E1, Ethernet or Data over E3 or Fiber Multiplexer

Ordering

OP-34/?/+/*/%/\$/#/&

Legend

- ? E1 connector:
- B Balanced (RJ-45, 1U-high unit)
 - U Unbalanced (BNC, 2U-high unit)
 - UBR Unbalanced (IEC-169/13, 2U-high unit)
- + Alarm port (Default=no alarm port):
- A Alarm port
- * Power supply:
- Note: Optimux-34 is supplied with one OP-34-PS wide range power supply.*
- R Dual power supply (110-240 AC, -48 VDC)
 - DC Single +24/-48 VDC
 - DCR Dual +24/-48 VDC
- % V.35 user port (Default=no V.35 user port):
- V35 DB-25 connector with ISO-2110 pinout
 - V35T DB-25 connector with Telebras pinout
- \$ Activation key (Default=no activation key):
- PACK1 Software key for activating the 10/100BaseT Ethernet port

*Note: It is strongly recommended to order this device with **original** RAD SFPs installed. This will ensure that prior to shipping, RAD has performed comprehensive functional quality tests on the entire assembled unit, including the SFP devices. RAD cannot guarantee full compliance to product specifications for units using non-RAD SFPs.*

- # Main link interface:
- SFP-12 Electrical coax, SMB
 - SFP-1 1310 nm, multimode, LED, LC connector
 - SFP-2 1310 nm, single mode, laser diode, LC connector
 - SFP-3 1310nm, single mode, long-haul laser diode, LC connector
 - SFP-4 1550 nm, single mode, long-haul laser diode, LC connector
 - SFP-10a Transmit 1310 nm, receive 1550 nm (WDM), LC connector
 - SFP-10b Transmit 1550 nm, receive 1310 nm (WDM), LC connector

Note: For single-fiber applications, a device with the SFP-10a interface should always be used opposite a device with the SFP-10b interface, and vice versa.

- & Redundant main link (Default=one main link):
- D Redundant main link

OP-34-PACK1

Software key for activating the 10/100BaseT Ethernet port

OP-34-PACK1-DEMO

Evaluation software key for activating the 10/100BaseT Ethernet port (expires after 30 days)

OP-34-PS

Wide range 100-240 VAC/-48 VDC power supply module for adding a redundant power supply to an existing unit or replacing the original power supply module

SUPPLIED ACCESSORIES

AC/DC power cord

RM-34

Kit for mounting one 1U-high unit in a 19-inch rack (supplied with balanced unit only)

RM-36

Kit for mounting one 2U-high unit in a 19-inch rack (supplied with unbalanced unit only)

CBL-DB9F-DB9M-STR

Control port cable

CBL-SMB-BNC/M

SMB to BNC adapter cable (supplied with SFP-12)

OPTIONAL ACCESSORIES

OP-34-PS-BP

Blank panel for power supply module

CBL-RJ45/BNC/E1/X

RJ-45 to BNC adapter cross-cable (for use with 1U chassis)

CBL-8H/M/1METER

V.35, DB-25 to M-34 cable

International Headquarters

24 Raoul Wallenberg Street
Tel Aviv 69719, Israel
Tel. 972-3-6458181
Fax 972-3-6498250, 6474436
E-mail market@rad.com

North America Headquarters

900 Corporate Drive
Mahwah, NJ 07430, USA
Tel. 201-5291100
Toll free 1-800-4447234
Fax 201-5295777
E-mail market@radusa.com

www.rad.com



data communications

The Access Company