

LA-210

EFM DSL Network Termination Unit



Delivering Ethernet services over G.SHDSL.bis lines using EFM technology

- G.SHDSL.bis EFM network termination unit, supporting up to 22 Mbps over copper infrastructure
- Designed for large and small-to-medium enterprises to deliver business-class Ethernet services
- MEF certified supporting Ethernet Private Line (EPL) and Ethernet Virtual Private Line (EVPL) services with flexible mapping of the user traffic into Ethernet flows
- Robust bandwidth control mechanism and SLA monitoring per Ethernet flow assure delivery of contracted Ethernet services
- Ethernet OAM based on IEEE 802.1ag and ITU-T Y.1731

EtherAccess

LA-210 is an advanced DSL Ethernet access device operating at data rates of up to 22 Mbps using G.SHDSL.bis EFM bonding technology. LA-210 enables carriers to deliver state-of-the-art Ethernet services while leveraging the existing copper infrastructure and DSLAM deployments.

In addition to the EFM mode, LA-210 operates the SHDSL link in ATM mode to be compatible with the existing DSLAM infrastructure.

LA-210 has one or four 10/100BaseT Ethernet ports and up to four pairs of SHDSL (EFM) links.

Designed to deliver business-class Ethernet services, LA-210 operates in the bridge and flow-to-EVC mapping modes.

BRIDGE MODE

The internal bridge operates in VLAN aware and VLAN unaware modes.

VLAN stacking can be used for traffic separation between different users or services, by defining a Service VLAN ID per customer or service. When VLAN stacking is used, a Service VLAN tag is added to the user traffic and removed from network traffic. Both Service VLAN ID and Service VLAN priority can be defined.



RAD

data communications

The Access Company

LA-210

EFM DSL Network Termination Unit

FLOW MAPPING TO EVC

Incoming customer traffic is mapped to the Ethernet flows (EVCs) using the following per-port criteria:

- Port-based (All-to-one bundling)
- Customer VLAN ID
- Customer VLAN priority
- DSCP
- IP Precedence.

Each flow can either have a single service assigned to it or up to 8 services which are differentiated by the SP-VLAN P-bits (flow.CoS).

TRAFFIC PRIORITIZATION

LA-210 supports enhanced traffic prioritization and QoS to ensure service level agreements (SLA) that comply with business customer's high demands.

Traffic policing is applied per service and operates according to the dual leaky bucket mechanism based on CIR + CBS and EIR + EBS. User traffic is mapped into up to four separate queues, which can be configured to work as strict priority or weighted fair queue (WFQ).

The queues handle traffic with different service demands, such as real-time traffic, premium data or best-effort data.

Rate limitations are applied at the port and queue levels.

ETHERNET OAM

LA-210 provides two types of Ethernet OAM:

- End-to-end OAM based on IEEE 802.1ag and ITU-T Y.1731 enable Ethernet service providers to monitor their services proactively, measure end-to-end performance and guarantee that the customers receive the contracted SLA. Fault monitoring and performance measurement include Frame Delay, Frame Delay Variation, Frame Loss and Availability
- Single segment (link) OAM according to IEEE 802.3ah fault indication, including remote loopback.

MANAGEMENT CAPABILITIES

The unit can be managed using different ports and applications:

- Remote inband management via the network ports using Telnet, Web browser or RADview, RAD's SNMP-based management system
- Out-of-band management via one of the user data ports that can be configured as management port
- Local management via an ASCII terminal connected to the RS-232 port.

Management traffic can be separated from user data by creating a dedicated management VLAN.

Up to ten different stations can manage LA-210 monitoring the network status from different locations.

SECURITY

LA-210 ensures client-server communication security and correct user authentication using the following protocols:

- RADIUS (client authentication only)
- SSL for Web-based management application
- SSH for Secure Shell communication session
- Password protected Telnet, Web and local terminal access.

TYPICAL APPLICATIONS

LA-210 is a suitable match for corporate, small-medium enterprise and SOHO customers, which require robust and secure connectivity using Layer 2 VPN or LAN connectivity. LA-210 is designed to meet those requirements by utilizing MEF-defined applications:

- Ethernet Private Line (EPL) – site-to-site connectivity over dedicated bandwidth without service multiplexing (see Figure 1)
- Ethernet Virtual Private Line (EVPL) – site-to-site connectivity over shared bandwidth with service multiplexing (see Figure 2).

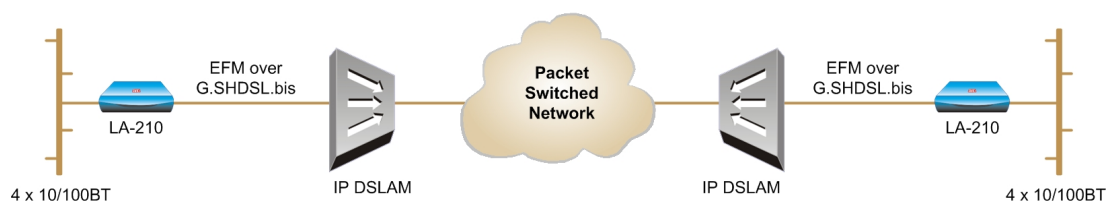

Figure 1. Connecting LANs via Ethernet Private Line (EPL) Service

Specifications

NETWORK INTERFACE

Type

G.SHDSL.bis

Line Coding

16 or 32 TC-PAM

Line Rate

192–5696 kbps, see table to the right

Impedance

135Ω

Typical Ranges (26 AWG)

Data Rate [kbps]	2-wire		4-wire		4x2-wire	
	[km]	[mi]	[km]	[mi]	[km]	[mi]
192	8	4.9	8	4.9	8	4.9
512	6.4	3.9	6.7	4.1	6.7	4.1
1536	5.7	3.5	6	3.7	6.5	4
2048	5.1	3.1	5.7	3.5	6.4	3.9
4096	3.9	2.4	5.1	3.1	5.7	3.5
4608	3.5	2.1	5	3	5.5	3.4
5696	2.9	1.8	4.6	2.8	5.1	3.1
11392	---	---	2.9	1.8	4.6	2.8
17088	---	---	---	---	3.5	2.1
22784	---	---	---	---	2.9	1.8

Compliance

ITU-T G.991.2, ETSI TS 101524

Bonding

Interface: 2Base-TL

Compliance: IEEE 802.3ah, ITU-T G.998.2

USER ETHERNET INTERFACE

Number of Ports

1 or 4

Type

10/100BaseT

Connector

RJ-45

GENERAL

Compliance

IEEE 802.3, 802.3u, 802.1D, 802.1Q, 802.1p, 802.3ah, MEF 9 and MEF 14

Max. Frame Size

1580 bytes

MAC Address Table Size

1024 entries

Management

- Local terminal port (V.24/RS-232 DCE; 9.6, 19.2, 115.2 kbps; DB-9 female connector)
- Inband: Via network traffic using a dedicated VLAN
- Out-of-band: Via one of the user data ports configured as management port

Power

AC/DC: 100–240 VAC, 50/60 Hz or 48/60 VDC nominal (40–72 VDC)

Power Consumption

2-wires: 5.9 W

4-wires: 6.5 W

8-wires: 7 W

Physical

Height: 43.7 mm (1.7 in)

Width: 217 mm (8.5 in)

Depth: 170 mm (6.7 in)

Weight: 0.5 kg (1.1 lb)

Environment

Temperature: 0–50°C (32–122°F)

Humidity: Up to 90%, non-condensing

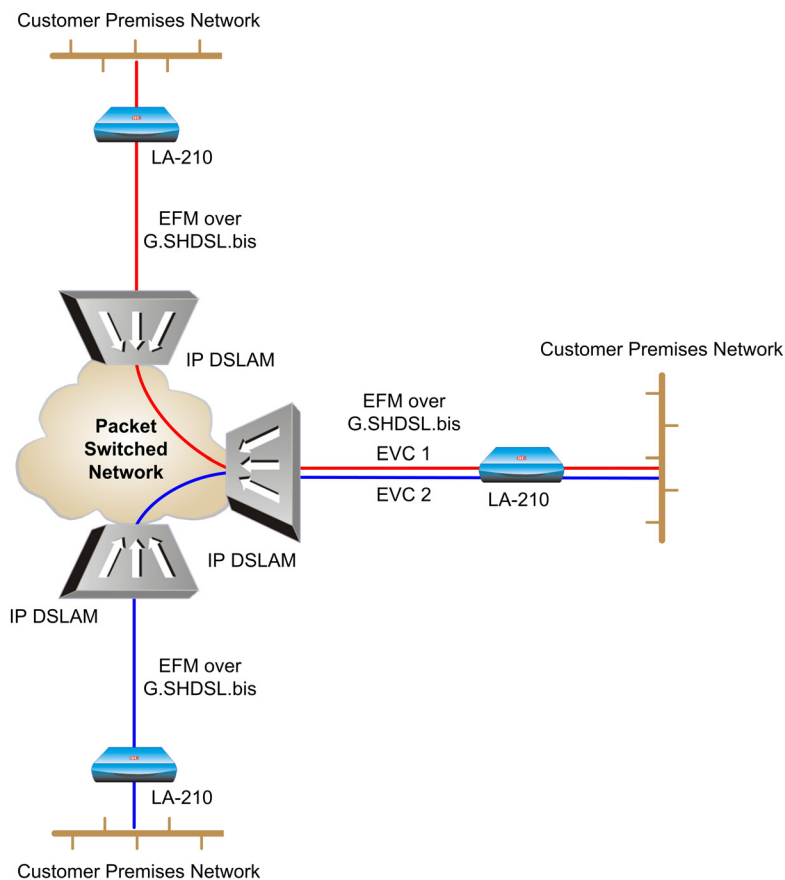

Figure 2. Providing L2 VPN using Ethernet Virtual Private Line (EVPL) Service

LA-210

EFM DSL Network Termination Unit

Ordering

LA-210/ESHDSL/!/\$/*/@/#

Legend

! SHDSL interface type:

2W 2-wire SHDSL interface**4W** 4-wire SHDSL interface**8W** 8-wire SHDSL interface

\$ Layer 2 over SHDSL type

EFM EFM only (no ATM support)**EA** EFM and ATM support

* Number of Ethernet ports:

1ETH One Ethernet port**4ETH** Four Ethernet ports

@ TDM port type:

E1 One E1 port**T1** One T1 port

Serial port type:

V35 V.35 port**X21** X.21 port

***Note:** Currently the E1 and serial ports are supported by the LA-210 hardware only. The ports become operational in the future software releases.*

SUPPLIED ACCESSORIES

AC power cord

OPTIONAL ACCESSORIES

RM-33-2

Hardware kit for mounting one or two LA-210 units into a 19-inch rack

CBL-DB9F-DB9M-STR

Control port cable

International Headquarters

24 Raoul Wallenberg Street
Tel Aviv 69719, Israel
Tel. 972-3-6458181
Fax 972-3-6498250, 6474436
E-mail market@rad.com

www.rad.com

North America Headquarters

900 Corporate Drive
Mahwah, NJ 07430, USA
Tel. 201-5291100
Toll free 1-800-4447234
Fax 201-5295777
E-mail market@radusa.com



data communications

The Access Company