

FOMi-E3, FOMi-T3

E3, T3, and HSSI Manageable Fiber Optic Modems

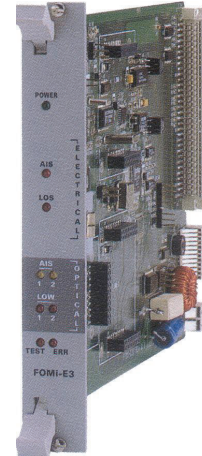

Transparently
transmit E3, T3
or HSSI signals over
multimode and
single-mode fiber
optic cables

- Extend the range of E3, T3 or HSSI services over fiber optic cables up to 110 km (68 miles)
- Fiber optic redundancy for better service availability
- Transparent to E3, T3 and HSSI framing
- Single modem card version for RAD's LRS-24, modem rack with SNMP management (except for HSSI option)
- Operate opposite RAD's Optimux-34 and Optimux-45 multiplexers (data only)

FOMi-E3 and FOMi-T3 are intelligent fiber optic modems designed for the transparent transmission of E3, T3, or HSSI signals over multimode and single-mode fiber optic cables.

The modems operate with a wide range of fiber optic interfaces over multimode and single-mode fiber optic cables (see *Table 1*).

The modems with E3 or T3 electrical interfaces are available with a station clock module that allows them to be synchronized with a central system clock. The station clock E1 and T1 inputs are 2.048 Mbps and 1.544 Mbps, respectively.

FOMi-E3 and FOMi-T3 operation complies with ITU-T G.703, G.921 and G.955 requirements.



data communications

Innovative Access Solutions

FOMi-E3, FOMi-T3

E3, T3, and HSSI Manageable Fiber Optic Modems

Four models are available:

- FOMi-E3 with E3 interface, 34.368 Mbps internal clock, and HDB3 coding
- FOMi-T3 with T3 interface, 44.736 Mbps internal clock, and B3ZS coding
- FOMi-E3/HSSI with E3 internal clock and data rates of 34.368, 17.184, 8.592 Mbps
- FOMi-T3/HSSI with T3 internal clock and data rates of 44.736, 22.368, 11.184 Mbps.

FOMi-E3/HSSI and FOMi-T3/HSSI contain an HSSI interface card that acts as a DCE interface. These modems do not support the station clock option.

The HSSI option also supports bit rates of one-half and one-fourth of the main link rate. This option enables connection of high-speed HSSI routers over public backbones at E3 or T3 rates.

The modems support a wide range of optical interfaces that operate at various wavelengths over single-mode and multimode cables as well as a variety of physical connectors (ST, FC/PC, SC, and SC/APC), detailed in *Table 1*.

A dual fiber optic interface allows full redundancy on the fiber optic transmission. A switchover mechanism activates immediately when signal loss on one of the dual optical links is detected.

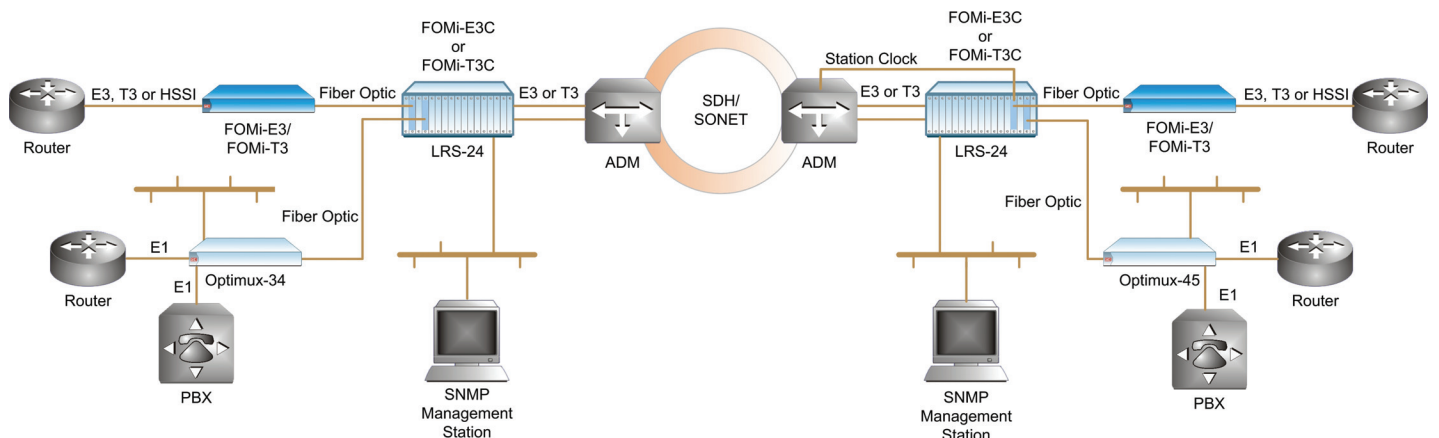

Figure 1. FOMi-E3 or FOMi-T3 Working Opposite RAD's Optimux Multiplexers

FOMi-E3 operates opposite RAD's Optimux-34 which multiplexes up to 16 E1 channels or a combination of E1 and Ethernet ports into a single fiber optic link (see *Figure 1*).

FOMi-T3 operates opposite RAD's Optimux-45, which integrates up to 28 T1, 21 E1, or any combination of T1 and E1 channels, over a single 45 Mbps data stream.

Remote FOMi-E3 and FOMi-T3 modems are managed using a proprietary inband channel over the fiber link. The operation of the management channel does not interfere with data transmission.

The modems are also available as modem cards for RAD's LRS-24, 19-inch SNMP-managed modem rack that accommodates up to ten modem cards without redundant fiber links or seven with redundant fiber optic links.

The modem cards and attached remote FOMi-E3 and FOMi-T3 units are managed using RADview, RAD's SNMP network management system. The standalone units are also managed via ASCII terminal.

A dry contact alarm relay for activating external alert devices in case of major or minor alarms is available on the rear panel of the standalone modem or on the common logic card of the LRS-24.

Redundant power supplies are optionally available.

Table 1. FOMi-E3, FOMi-T3 Fiber Optic Interface Characteristics

Wavelength [nm]	Fiber Type [μm]	Transmitter Type	Typical Power Output [dBm]	Receiver Sensitivity [dBm]	Connector	Typical Max. Range	
						[km]	[mi]
850	62.5/125 multimode	VCSEL	-18	-26	ST	2.5	1.5
1310	62.5/125 multimode	LED	-18	-31	ST, SC	5.5	3.4
1310	9/125 single mode	Laser	-12	-31	ST, SC, FC	38.0	23.6
1310	9/125 single mode	Laser (long haul)	-2	-34	ST, SC, FC	65.0	40.3
1550	9/125 single mode	Laser	-12	-31	ST, FC	25.0	15.5
1550	9/125 single mode	Laser (long haul)	-2	-34	ST, SC, FC	110.0	68.0
Tx/Rx 1310/1550	9/125 single mode	Laser (WDM), SF1	-12	-29	SC	40.0	25.0
Tx/Rx 1550/1310	9/125 single mode	Laser (WDM), SF2	-12	-29	SC	40.0	25.0
Tx/Rx 1310/1310	9/125 single mode	Laser, SF3	-12	-27	SC/APC	20.0	12.5

Specifications

DTE INTERFACE

Data Rate

E3: 34.368 Mbps

T3: 44.736 Mbps

HSSI-E3: 8.592, 17.184 or 34.368 Mbps

HSSI-T3: 11.184, 22.368 or 44.736 Mbps

Line Code

E3: HDB3

T3: B3ZS

Impedance

E3/T3: 75Ω, unbalanced

HSSI: 110Ω

Range

E3/T3: According to ITU-T Rec. G.703

HSSI: 2m (6.5 feet), nominal

Connectors

E3/T3: Two shielded BNC connectors
(unbalanced)

HSSI: One SCSI-50

FIBER OPTIC INTERFACE

Standard

ITU-T Rec. G.955

Line Code

CDP

Specifications and Ranges

See *Table 1*

Redundancy

Additional link is optional

STATION CLOCK

Input Data Rate

E1: 2.048 Mbps

T1: 1.544 Mbps

Line Code

AMI or Square

Impedance

75Ω, unbalanced

Connectors

Two shielded BNC

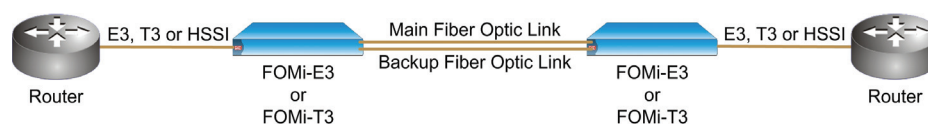

Figure 2. Point-to-Point Configuration

FOMi-E3, FOMi-T3

E3, T3, and HSSI Manageable Fiber Optic Modems

INDICATORS

- PWR (dual color LED) –
Green: Power operating correctly
Red: Power fault
- ELECTRICAL LOS (red) –
On: E3/T3 or HSSI electrical signal not detected
- ELECTRICAL AIS (red) –
On: AIS detected on the electrical link (not available for HSSI interface)
- OPTICAL LOW (red) –
On: signal loss detected in fiber optic line
- OPTICAL AIS (yellow) –
On: AIS detected on fiber optic link
- ERR (red) –
On: General error
- TTST (red)–
On: A test is active

DIAGNOSTICS

- Loopbacks**
Local analog (LLB)
Remote digital (RLB)
Local digital loopback (DIG)
Dual LLB+DIG (DLB)
Router loopback (LC), for units with HSSI interface only
- Statistics collection**
BPV (electrical), LCE (fiber optic)
PSES (electrical and fiber optic)
UAS (electrical and fiber optic)

GENERAL

- Control Port**
V.24 (RS-232) DTE, operating at 9.6 kbps to 115.2 kbps
- Control Port Connector**
D-type, 9-pin, female
- Alarm Relay Port**
Dry contact via 9-pin, D-type, female connector
Operates as Normally Open and Normally Closed, using different pins
- Power**
One or two power supplies with redundancy
AC: 100 VAC to 240 VAC, 50/60 Hz
-48 VDC: -36 VDC to -72 VDC
24 VDC: 24 VDC ± 10%
Power consumption: 15 W max.
- Physical**
Height: 4.4 cm (1.7 in)
Width: 42.7 cm (17.0 in)
Depth: 25.8 cm (10.1 in)
Weight: 2.5 kg (5.5 lb) full configuration

Table 2. Fiber Optic Modem Comparison Chart

Feature	FOM-E1/T1	FOMi-E1/T1	FOM-20	FOM-40	FOMi-40	FOM-E3/T3	FOMi-E3/T3	FOM-E3/T3 ETH
Data Rates [kbps]	E1/T1	E1/T1	19.2–256	56–2048	56–2048	E3/T3	E3/T3	E3/T3
Interfaces	G.703	G.703	Serial, Ethernet	Serial, Ethernet	Serial, Ethernet, E1/T1	G.703	G.703, HSSI	10/100BaseT VLAN Bridge
Laser Diode Option	✓	✓	✓	✓	✓	✓	✓	✓
SNMP Management		✓			✓		✓	
Card Version for Rack	ASM-MN-214	LRS	ASM-MN-214	ASM-MN-214	LRS		LRS	

FOMi-E3, FOMi-T3

E3, T3, and HSSI Manageable Fiber Optic Modems

Ordering

FOMi-E3/*/#/£/\$/^

E3 and HSSI manageable fiber optic standalone modem

FOMi-T3/*/#/£/\$/^

T3 and HSSI manageable fiber optic standalone modem

FOMi-E3CF/#/£/\$

E3 manageable fiber optic modem card for LRS-24 ETSI version

FOMi-E3CB/#/£/\$

E3 manageable fiber optic modem card for LRS-24 ANSI version

FOMi-T3CF/#/£/\$

T3 manageable fiber optic modem card for LRS-24 ETSI version

FOMi-T3CB/#/£/\$

T3 manageable fiber optic modem card for LRS-24 ANSI version

Legend

*	Power supply
AC	110–230 VAC
ACR	Redundant 110–230 VAC
24	24 VDC
24R	Redundant 24 VDC
48	–48 VDC
48R	Redundant –48 VDC
#	Fiber optic connector:
ST	ST
SC	SC
FC	FC/PC
	<i>Note: For SF1, SF2, and SF3 interfaces, only the SC connector is available.</i>
£	Optical wavelength
85	850 nm, multimode, VCSEL
13MM	1310 nm, multimode, LED
13L	1310 nm, single mode, laser diode
13LH	1310 nm, single mode, long-haul laser diode
15L	1550 nm, single mode, laser diode
15LH	1550 nm, single mode, long-haul laser diode
SF1	1310 nm transmit and 1550 nm receive (over single fiber)
SF2	1550 nm transmit and 1310 nm receive (over single fiber)
SF3	1310 nm transmit and 1310 nm receive (over single fiber)

Note: For single fiber connection (WDM), one of the devices must be ordered with an SF1 interface and the other with an SF2 interface.

\$	R	Redundant fiber optic link (see # and £, above, for options)
^		Station clock or HSSI (standalone units only)
STC		Station clock (not available for units with HSSI interface)
HSSI		HSSI

International Headquarters

24 Raoul Wallenberg Street
Tel Aviv 69719, Israel
Tel. 972-3-6458181
Fax 972-3-6498250, 6474436
E-mail market@rad.com

North America Headquarters

900 Corporate Drive
Mahwah, NJ 07430, USA
Tel. 201-5291100
Toll free 1-800-4447234
Fax 201-5295777
E-mail market@radusa.com

www.rad.com



data communications

Innovative Access Solutions